



Motion The Future



LTROBOT

Tel: +86-512-66317439

Address: 22-4 Que mei dongroad, Mudu town,
wuzhong district, Suzhou, Jiangsu, China.

Website: www.opalmotion.com

Email: Linearguide@opalmotion.com

Linear guide
Miniature(steel/stainless steel)
C7 Rolled ball screw
C3 C5 Ground ball screw



SG High Capacity Linear Guide

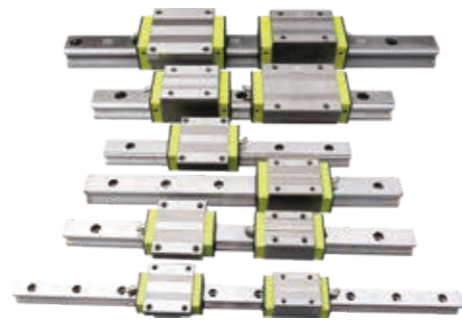

LDH Starclard Linear Guide



LDM Miniature



LDM**M Miniature



C7 Rolled Ball Screw



C3 C5 Ground Ball Screw



Company culture

Culture: Morality, Quality, Brand
Promote intelligent manufacturing in China 2025
Vision: Leading the development of linear motion
Value: Innovation, Honest, Win-win, Brave mission

COMPANY PROFILE

LTROBOT, part of the Fujian Linear Group, a manufacturer from China. Since 2008, we have been producing linear transmission components including linear guides block from 15 to 65, rail length from 4 meters to 6 meters, ground ball screw C3 C5 accuracy and rolled ball screw C7 accuracy.

Currently we have 2 sites, 32 production lines, 182 people working, and keep workshop whole day full running.

[Quality,Quality and Quality]

We have an extensive selection of linear guides and ball screws. While our prices are competitive, we in no way sacrifice product QUALITY for any batches.

Focus on customer service QUALITY. You will always be able to deal with real people if you have questions, need technical advice or encounter any problems.

We make high QUALITY Relationship with our distributors by "1 partner 1 region only" policy. We understand the competitive nature and rules of the industrial field.

To discuss your next project, please message us or email us at linearguide@opalmotion.com.

LTROBOT series products provide optimum system rigidity through preloaded O-arrangement, fast mounting SUS304 cover strip, dust proof design and minimum quantity lubrication system with integrated reservoir. Our continuous improvement in the future will make our products more outstanding.

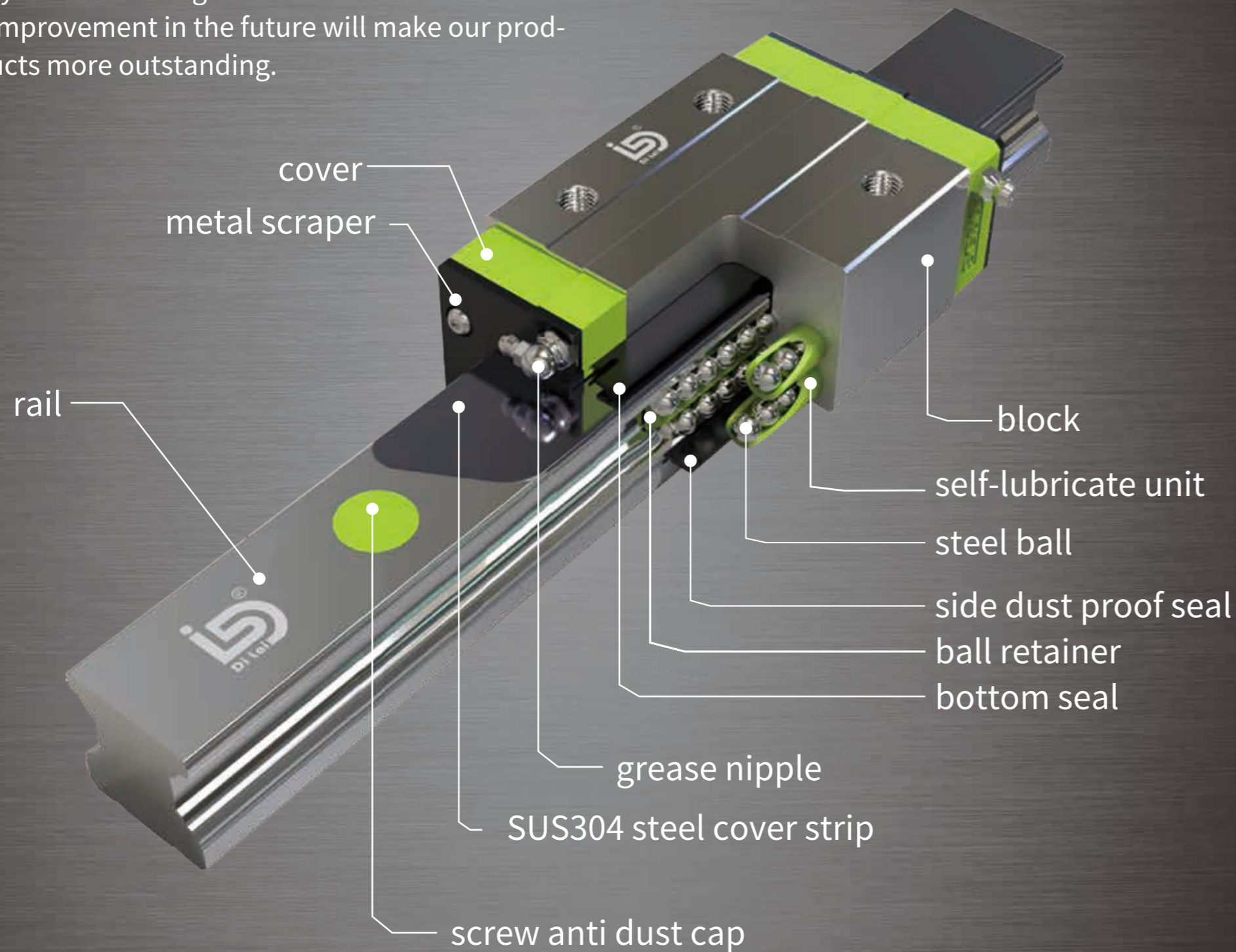

CONTENTS

Part one: Linear guide

1-1 SG High Capacity Linear Guide	01
1-1-1 SG series product advantages	01
1-1-2 SG series specifications	02
1-1-3 SG series block and rail type	04
1-1-4 Accuracy class	05
1-1-5 SG high moment linear guide	08
1-1-6 SG steel cover strip introduction and related accessories ..	10
1-2 LDH , LDE Standard Linear Guide.....	12
1-2-1 LDH heavy load ball type linear guide	12
1-2-2 LDE low profile ball type linear guide	22

Part two: Miniature Linear guide

2-1 LDM series miniature linear guide	30
---	----

Part three: Ball Screw

3-1 Features of LTROBOT Ball Screw	34
3-2 Ball Screw Selection Procedure	36
3-3 Accuracy	36
3-4 Positioning Accuracy	43
3-5 Service Life Design	44
3-6 Cautions About Use of Ball Screws	46
3-7 Nominal Model Code of Ball Screw	49
3-8 Ground Ball Screw Series	52
3-8-1 LTROBOT Nut of Precision Ground Ball Screw Type	52
3-9 Rolled Ball Screw	71
3-9-1 Rolled Screw	71
3-9-2 The Features of LTROBOT Rolled Ball Screw	71
3-9-3 Nominal Model Code of Rolled Ball Screws	71
3-9-4 Preload of Rolled Ball Screw	74
3-10 Rolled Ball Screw Series	75
3-10-1 LTROBOT Nut of Rolled Ball Screw Type	75

Part four: Product brand interchange details

.....	88
-------	----

1-1 High Moment Ball Linear Guide Features

NO.1

The SG block arc groove SG (45X45) combination has a longer anti-torque arm ($A1 > A$) than the old LD groove, and has extremely high rigidity in all load directions, which improves the rated load and rated torque



NO.2

Cover strip for ball guide rail mounting holes are made of stainless steel SUS304 directly improve the linear guide beauty and smoothness, easy to clip it on and secure it and can meet the needs of high dust occasions

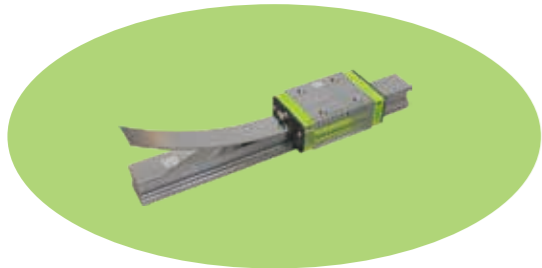

NO.3

The purpose of seals is to prevent dirt, chips, metalworking fluids, etc. from entering the ball block and thus shortening its service life

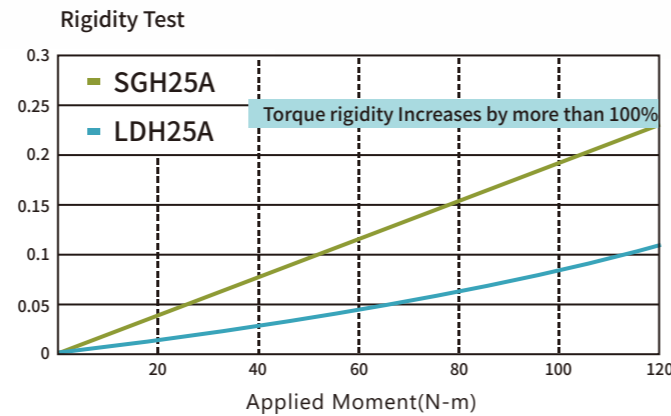
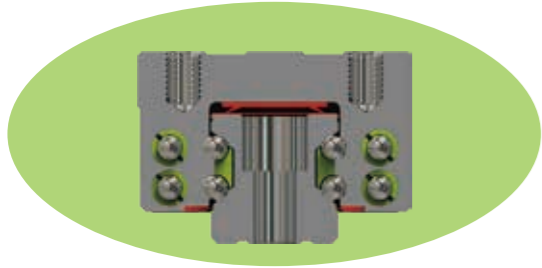

NO.4

Minimum quantity lubrication system with integrated reservoir for oil lubrication

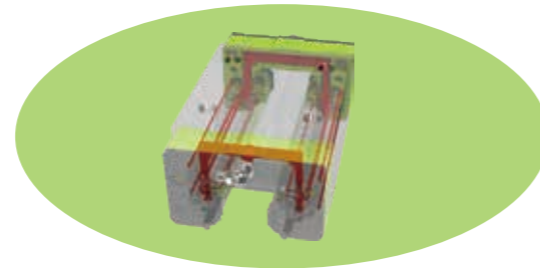

NO.5

Low noise and better smoothness due to integrated silent backflow structure design



Construction

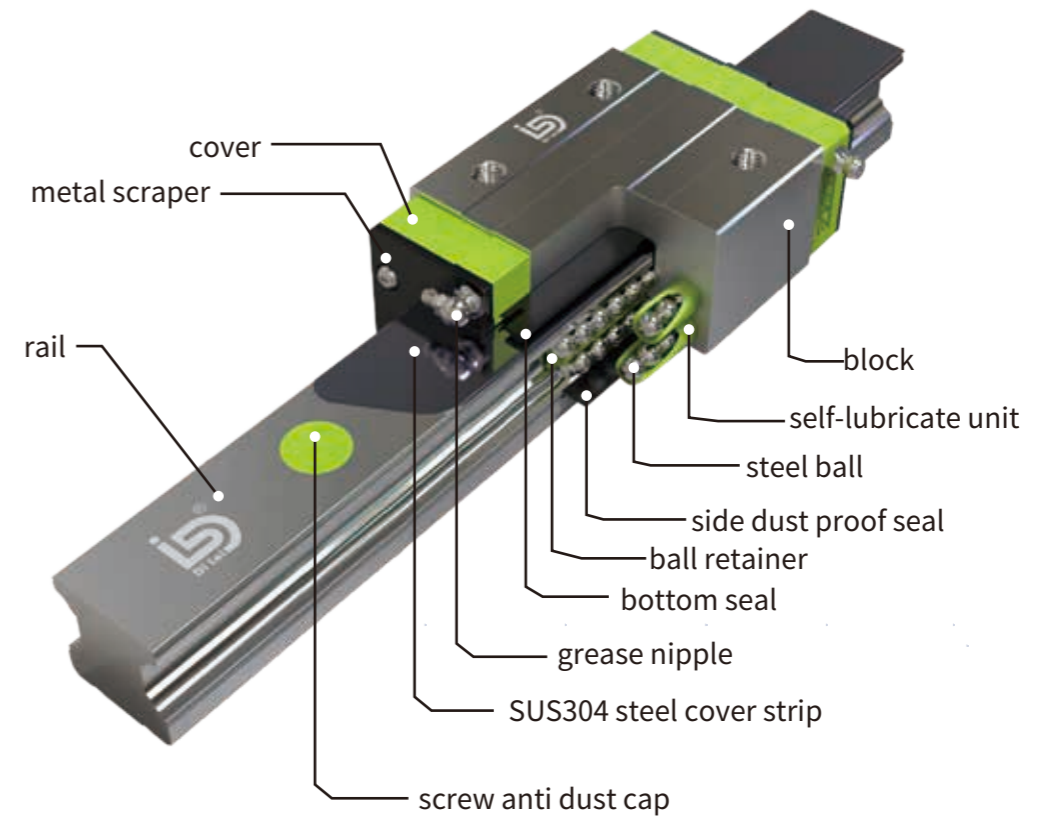

- Rolling circulation system: block, rail, cover, ball, ball retainer
- Lubricant system: self-lubricate unit, grease nipple, tubing joint
- Dust protection system: SUS304 steel cover strip, end seal, bottom seal, screw

1-1-2 Specifications

LT series products are divided into two types of linear guides, which are non-interchangeable and interchangeable. Both type's dimension are the same. The main difference is the interchangeable rails and blocks can be used interchangeably, which is convenient, but the combination accuracy cannot achieve non-interchangeable ultra-high precision, because LT has good dimensional control and strict quality requirements in manufacturing, the interchangeable combination accuracy has reached a certain level, for customers who do not need to pair with linear guides it is a good choice. The product specifications of the linear guide mainly indicate the specifications of the linear guide rail size, type, accuracy grade, preload, etc., for confirming the product when ordering.

Non-interchangeable linear guide product model

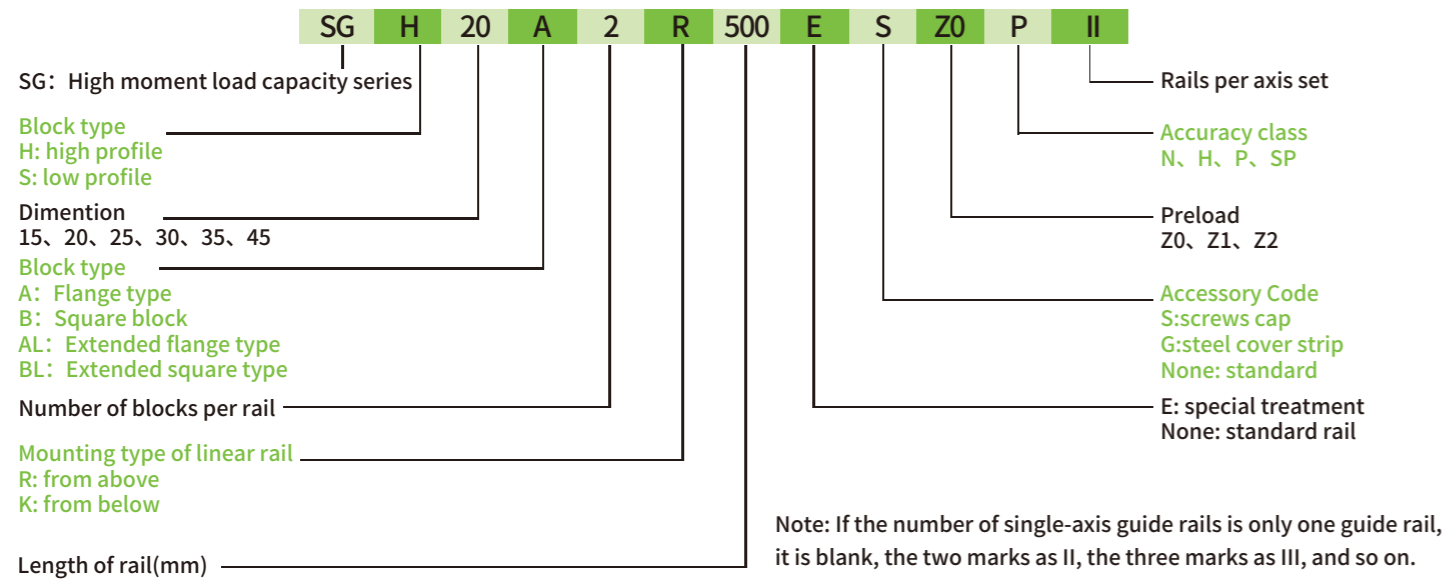

Interchangeable linear guide product model

Interchangeable type block product model

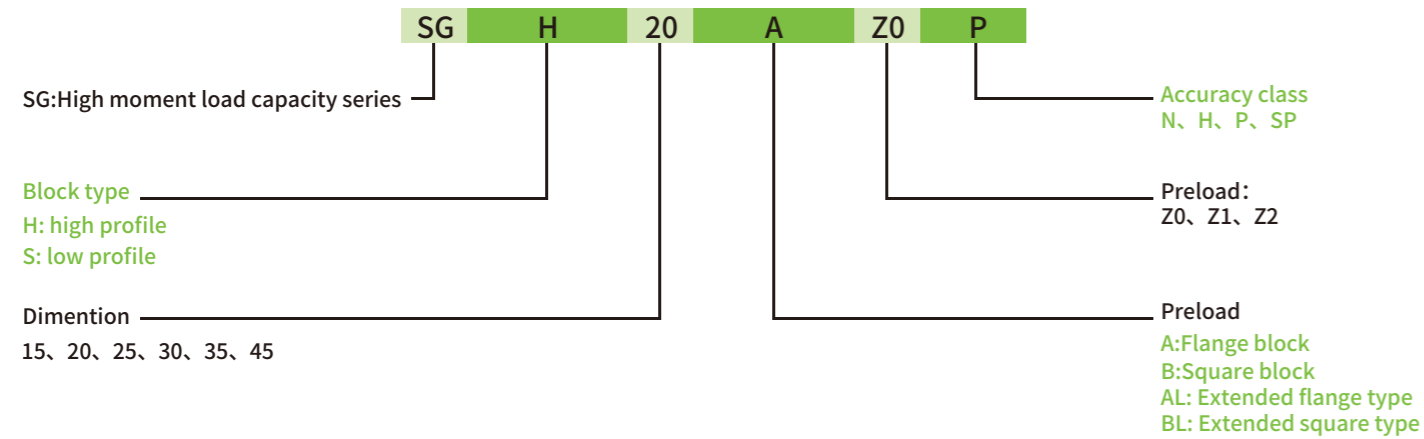

Interchangeable type rail product model

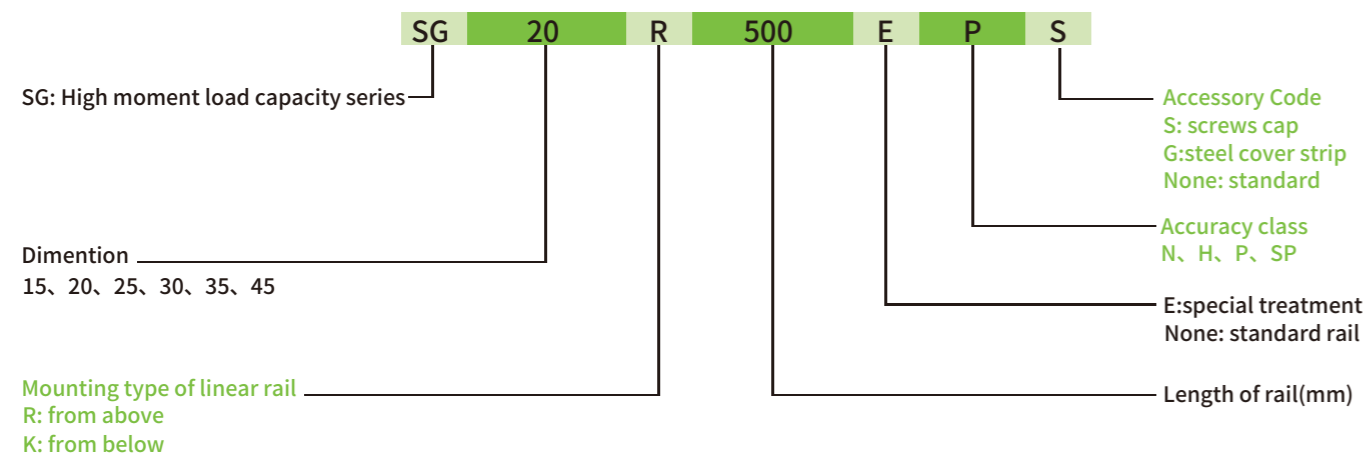

1-1-3 Block type

LTROBOT offers two types of blocks: flange and square

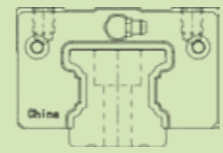
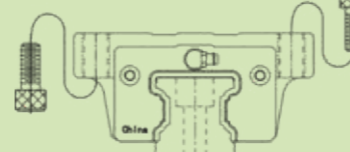
Type	Standard	Shape	Height dimension (mm)	Length of rail (mm)	Application equipment
Square block	SGH-B SGS-B		24 ↓ 70	100 ↓ 4000/6000	<ul style="list-style-type: none"> Machining center Machine tool Precision processing machine Heavy duty cutting machine Marble cutting machine Grinder
Flange block	SGH-A SGS-A		24 ↓ 60	100 ↓ 4000/6000	<ul style="list-style-type: none"> Injection molding machine Punch Automation Equipment Measuring instrument Woodworking and wood processing machines 3D printer Laser Printing Medical Clothing equipment

Category	Product model	Type				Feature			
		Flange mode	High profile square	Low profile square	Extended type	High moment capacity	Steel cover strip	Anti dust	Quiet
SG high moment load capacity	SG15 series	●	●	●		●			
	SG20 series	●	●	●	●	●	●	●	●
	SG25 series	●	●	●	●	●	●	●	●
	SG30 series	●	●	●	●	●	●	●	●
	SG35 series	●	●	●	●	●	●	●	●
	SG45 series	●	●	●	●	●	●	●	●

1-1-3 Linear guide type

In addition to the general from above lock bolt holes, LTROBOT also provides a from below lock bolt hole guide for easy installation and use.

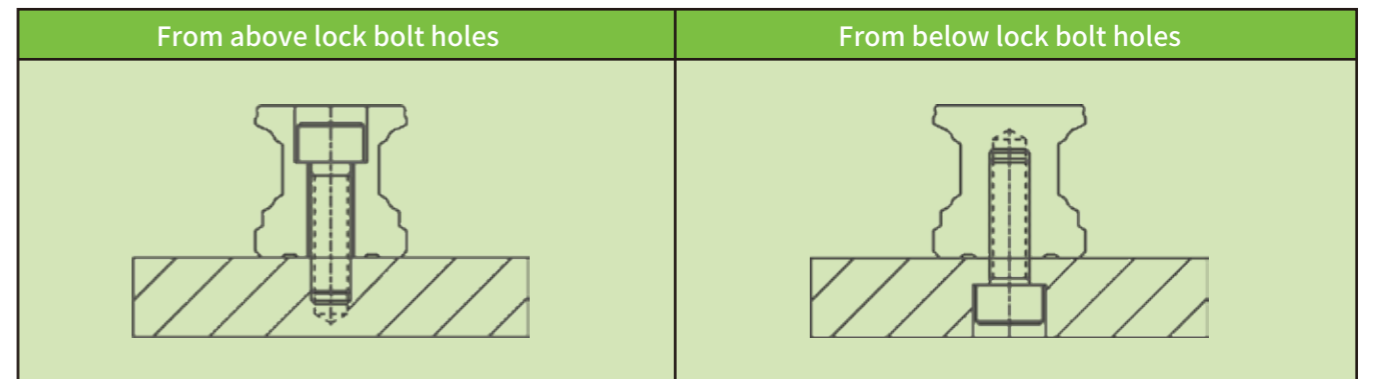

1-1-4 Accuracy class

The precision of SG series linear guides is divided into five levels: ordinary, high, precision, ultra-precision and ultra-high precision(N H P SP UP). Customers can select the precision according to the precision requirements of the equipment.

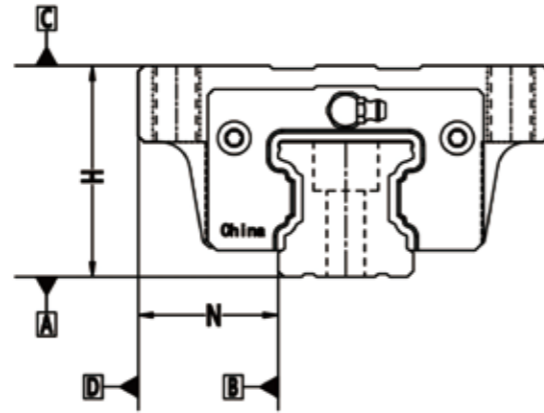

(1) Non-interchangeable linear guide accuracy

Assembly precision

Model	SG-15、20				
	Normal (N)	Senior (H)	Precision (P)	High precision(SP)	Ultra precision (UP)
Accuracy class					
Allowable dimensional error of height H	±0.1	±0.03	0 -0.03	0 -0.015	0 -0.008
Allowable size error of width N	±0.1	±0.03	0 -0.03	0 -0.015	0 -0.008
Mutual error of pair height H	0.02	0.01	0.006	0.004	0.003
Mutual error of pairwise width N	0.02	0.01	0.006	0.004	0.003
The parallelism of the block C facing the A side of the guide rail	Running parallelism				
The parallelism of the block D facing the B side of the guide rail	Running parallelism				

Assembly precision

Model	SG-25、30、35、45				
	Normal (N)	Senior (H)	Precision (P)	High precision(SP)	Ultra precision (UP)
Accuracy class					
Allowable dimensional error of height H	±0.1	±0.04	0 -0.04	0 -0.02	0 -0.01
Allowable size error of width N	±0.1	±0.04	0 -0.04	0 -0.02	0 -0.01
Mutual error of pair height H	0.02	0.015	0.007	0.005	0.003
Mutual error of pairwise width N	0.03	0.015	0.007	0.005	0.003
The parallelism of the block C facing the A side of the guide rail	Running parallelism				
The parallelism of the block D facing the B side of the guide rail	Running parallelism				

(2) Interchangeable linear guide accuracy

Interchangeable linear guide precision

Model	SG-15、20		
	Normal (N)	Senior (H)	Precision (P)
Accuracy class			
Allowable dimensional error of height H	±0.1	±0.03	0 ±0.015
Allowable size error of width N	±0.1	±0.03	0 ±0.015
Mutual error of pair height H	0.02	0.01	0.006
Mutual error of pairwise width N	0.02	0.01	0.006
The parallelism of the block C facing the A side of the guide rail	Running parallelism		
The parallelism of the block D facing the B side of the guide rail	Running parallelism		

Interchangeable linear guide precision

Model	SG-25、30、35、45		
	Normal (N)	Senior (H)	Precision (P)
Accuracy class			
Allowable dimensional error of height H	±0.1	±0.04	0 ±0.02
Allowable size error of width N	±0.1	±0.04	0 ±0.02
Mutual error of pair height H	0.02	0.015	0.007
Mutual error of pairwise width N	0.03	0.015	0.007
The parallelism of the block C facing the A side of the guide rail	Running parallelism		
The parallelism of the block D facing the B side of the guide rail	Running parallelism		

Running parallelism

(3) Running parallelism

Length of rail (mm)	Accuracy grade (μm)				
	N	H	P	SP	UP
~100	12	7	3	2	2
100~200	14	9	4	2	2
200~300	15	10	5	3	2
300~500	17	12	6	3	2
500~700	20	13	7	4	2
700~900	22	15	8	5	3
900~1100	24	16	9	6	3
1100~1500	26	18	11	7	4
1500~1900	28	20	13	8	4
1900~2500	31	22	15	10	5
2500~3100	33	25	18	11	6
3100~3600	36	27	20	14	7
3600~4000	37	28	21	15	7

Preload

(1) Definition of preload

The preload is to pre-send the load force of the steel ball, that is, increase the diameter of the steel ball, and use the negative gap between the steel ball and the steel ball track to pre-press, which can improve the rigidity of the linear guide and eliminate the gap; The pressure increases the rigidity of the linear guide. However, the small size is recommended to use the preload under the light preload to avoid the excessive use of preload to reduce its service life.

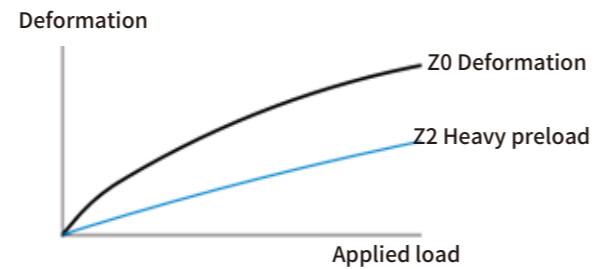

(2) Level of preload

Level of preload	Mark	Preload	Conditions of Use	Application of Scope
No preload	Z0	0-0.02C	Fixed load direction with low impact and low precision	Transfer device, automatic packaging machine, automation industrial machinery, XY axis for general industrial machinery, welding machine, fuse machine, tool changer
Middle preload	Z1	0.05C-0.07C	Light load and high precision	General industrial machinery Z-axis, electric discharge machine, NC machine tool, precision XY platform, measuring device, machining center, vertical machining center, industrial robot, automatic coating machine, various high-speed material supply devices
Heavy preload	Z2	0.10C-0.12C	Requirements for rigidity, vibration and impact	Machining center, grinding machine, NC lathe, vertical or horizontal milling machine, machine tool Z axis, heavy cutting machine
Level	Interchangeable linear guide		Non-interchangeable track (assembly)	
Level of preload	Z0,Z1		Z0,Z1, Z2	

Note: preload C is dynamic load capacity

1-1-5 SG series linear guide dimension table

○ SGH-A/SGH-AL/SGS-A

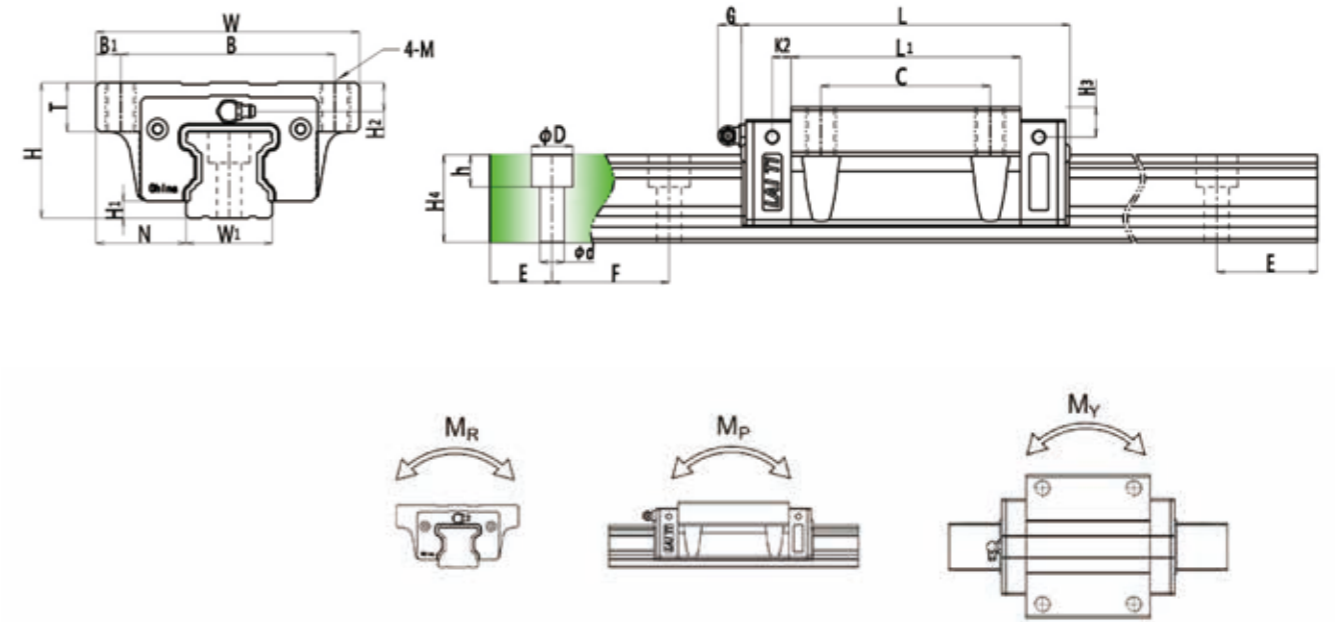

Linear Guide parameter

Note: 1kgf=9.81N

Model	Assembly dimension (mm)			Block dimension (mm)								Rail dimension (mm)							Basic dynamic load capacity C _{dyn} (kN)	Basic static load capacity C ₀ (kN)	Static permissible moment			
	H	H ₁	N	W	B	C	L ₁	L	MxL	H ₂	H ₃	W ₁	H ₄	D	h	d	F	E			M _R	M _P	M _Y	
																						KN-m	KN-m	KN-m
SGH15A	24	3	16	47	38	30	39.2	58.2	M5	4	3.6	15	14.9	7.5	5.3	4.5	60	20	14.23	18.35	0.19	0.14	0.14	
SGH20A	30	3.7	21.5	63	53	40	52.5	80	M6	5	5.8	20	20	9.5	8.5	6	60	20	23.96	30.87	0.37	0.28	0.28	
SGH20AL							65.2	93																28.86
SGS20A	28	3.7	19.5	59	49	32	52.5	80	M6	4	3.8	20	20	9.5	8.5	6	60	20	23.96	30.87	0.37	0.28	0.28	
SGH25A	36	4.5	23.5	70	57	45	61	85	M8	7.6	8	23	23	11	9	7	60	20	35.33	44.34	0.6	0.49	0.49	
SGH25AL							80.3	104.7																42.58
SGS25A	33	4.5	25	73	60	35	61	85	M8	4.6	5	23	23	11	9	7	60	20	35.33	44.34	0.6	0.49	0.49	
SGH30A	42	7	31	90	72	52	69	97	M10	6	7	28	28.4	14	12	9	80	20	46.25	55.91	0.95	0.7	0.7	
SGH30AL							92.3	120.3																58.89
SGS30A	42	7	31	90	72	40	69	97	M10	6	7	28	28.4	14	12	9	80	20	46.25	55.91	0.95	0.7	0.7	
SGH35A	48	7.6	33	100	82	62	79	109	M10	7.4	7.4	34	31.9	14	12	9	80	20	61.32	80.57	1.73	1.09	1.09	
SGH35AL							105	135																78.16
SGS35A	48	7.6	33	100	82	50	79	109	M10	7.4	7.4	34	31.9	14	12	9	80	20	61.32	80.57	1.73	1.09	1.09	
SGH45A	60	9.7	37.5	120	100	80	97.8	138	M12	8	8	45	39.85	20	17	14	105	22.5	98.43	112.66	3.56	2.35	2.35	
SGH45AL							132.3	173																125.58

SG series linear guide dimension table

○ SGH-B/SGH-BL/SGS-B

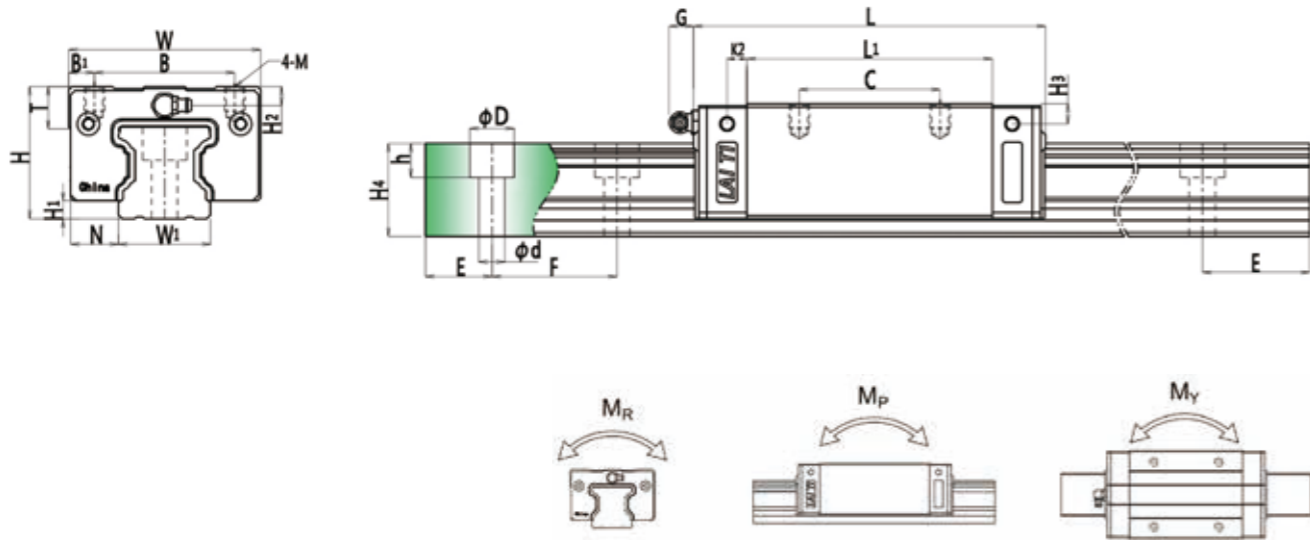

Linear Guide parameter

Note: 1kgf=9.81N

Model	Assembly dimension (mm)			Block dimension (mm)								Rail dimension (mm)								Basic dynamic load capacity $C_{dyn}(kN)$	Basic static load capacity $C_0(kN)$	Static permissible moment		
	H	H ₁	N	W	B	C	L ₁	L	MxL	H ₂	H ₃	W ₁	H ₄	D	h	d	F	E	M _R KN-m			M _p KN-m	M _y KN-m	
SGH15B	28	3	9.5	34	26	26	39.2	58.2	M4X5	8	7.6	15	14.9	7.5	5.3	4.5	60	20	14.21	18.53	0.19	0.14	0.14	
SGS15B	24	3	9.5	34	26	26	39.2	58.2	M4X5	4	3.6	15	14.9	7.5	5.3	4.5	60	20	13.56	17.65	0.19	0.14	0.14	
SGH20B	30	3.7	12	44	32	36	52.5	80	M5X6	5	5.8	20	20	9.5	8.5	6	60	20	24.23	31.28	0.37	0.28	0.28	
SGH20BL						50	65.2	93											27.66	39.42	0.48	0.48	0.48	
SGS20B	28	3.7	11	42	32	32	52.5	80	M5X6	4	3.8	20	20	9.5	8.5	6	60	20	24.23	31.28	0.37	0.28	0.28	
SGH25B	40	4.5	12.5	48	35	35	61	85	M6X8	11.6	12	23	23	11	9	7	60	20	35.24	44.31	0.60	0.49	0.49	
SGH25BL						50	80.3	104.7											42.58	57.86	0.74	0.73	0.73	
SGS25B	33	4.5	12.5	48	35	35	61	85	M6X8	4.6	5	23	23	11	9	7	60	20	19.38	23.04	0.60	0.49	0.49	
SGH30B	45	7	16	60	40	40	69	97	M8X10	9	10	28	28.4	14	12	9	80	20	46.53	56.24	0.95	0.7	0.7	
SGH30BL						60	92.3	120.3											58.89	78.88	1.35	1.23	1.23	
SGS30B	42	7	16	60	40	40	69	97	M8X10	6	7	28	28.4	14	12	9	80	20	27.92	33.74	0.95	0.7	0.7	
SGH35B	55	7.6	18	70	50	50	79	109	M8X12	14.4	14.4	34	31.9	14	12	9	80	20	61.22	80.30	1.73	1.09	1.09	
SGH35BL						72	105	135											78.16	113.64	2.46	2.02	2.02	
SGS35B	48	7.6	18	70	50	50	79	109	M8X12	7.4	7.4	34	31.9	14	12	9	80	20	39.79	52.20	1.73	1.09	1.09	
SGH45B	70	9.7	20.5	86	60	60	97.8	138	M10X17	18	18	45	39.85	20	17	14	105	22.5	98.43	112.66	3.56	2.35	2.35	
SGH45BL						80	132.3	173											125.58	159.6	5.05	4.45	4.45	

1-1-6 Stainless steel cover strip introduction and related accessories

1. Development specification model

Series	Specification
SG	20, 25, 30, 35, 45

2. Stainless steel cover strip advantages

- Stainless steel sus304
- Fast mounting
- Avoid damage to the oil scraper seal by bolt holes
- Prevent external dust from entering the block from the bolt hole

3. Dust-proof steel belt related accessories

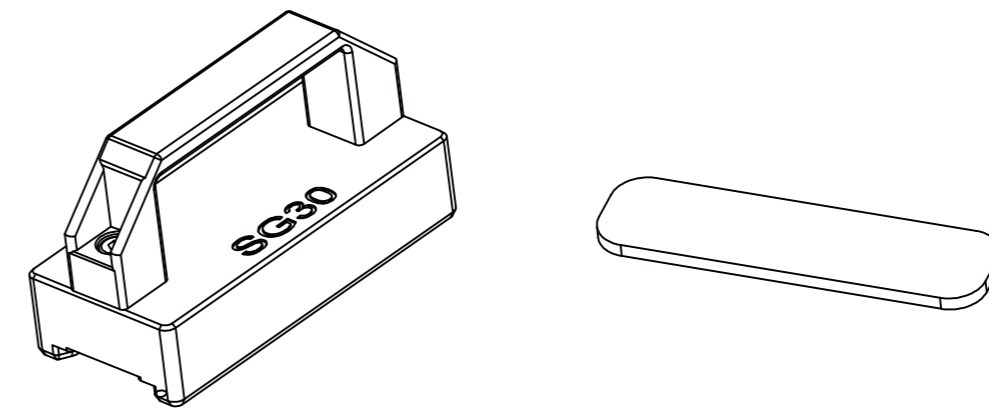

Steel belt installation tool

Steel strip removal tool

The SG dust-proof steel strip is mounted on the rails (the rail length is below four meters and is not connected)

1. Stainless steel strip mounting

A steel strip with a rail length of less than four meters will be snapped on to the rail directly.

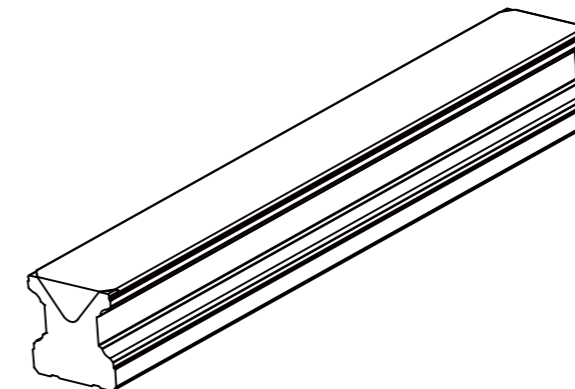

2.Remove the steel strip

When removing the steel strip, please avoid deforming the steel strip and creating creases. If the steel strip is creased, it will affect the protection. Please do not use it for recycling. LT also provides optional disassembly and assembly tools for users.

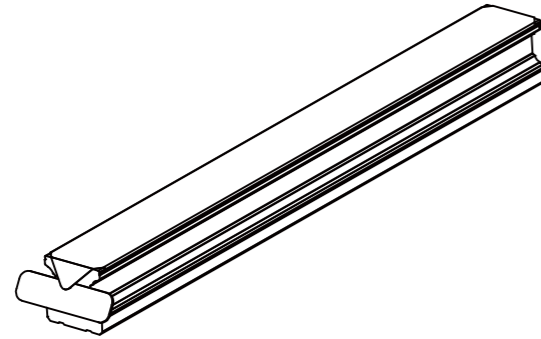

3.Fasten the steel belt

Option 1:

After aligning the front insert part of the steel strip with the end surface of the sliding rail, an external force is applied to both sides of the upper surface of the steel strip to make the steel strip closely adhere to the upper surface of the sliding rail.



If you use your hand for pressing, please put on gloves to avoid injury.

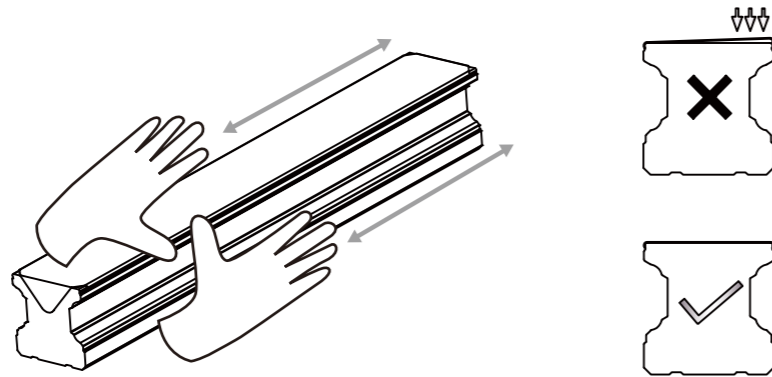

Option 2:

LTROBOT also offers optional installation tools. Align the front end bends with the end faces of the rails, fasten the front end of the strip to the rails, then insert the mounting tool and move it, and remove it from the other end.

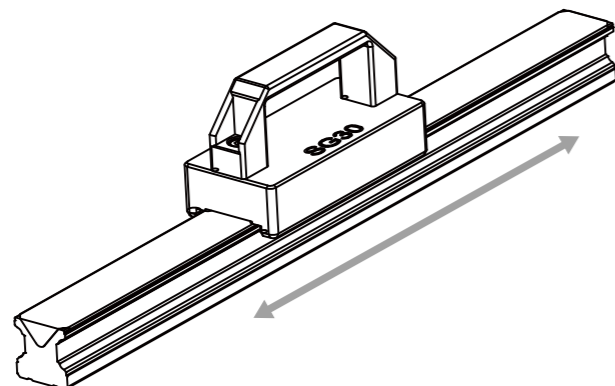

1-2 LDH Standard Linear Guides

1-2-1 Non-interchangeable linear guide product model

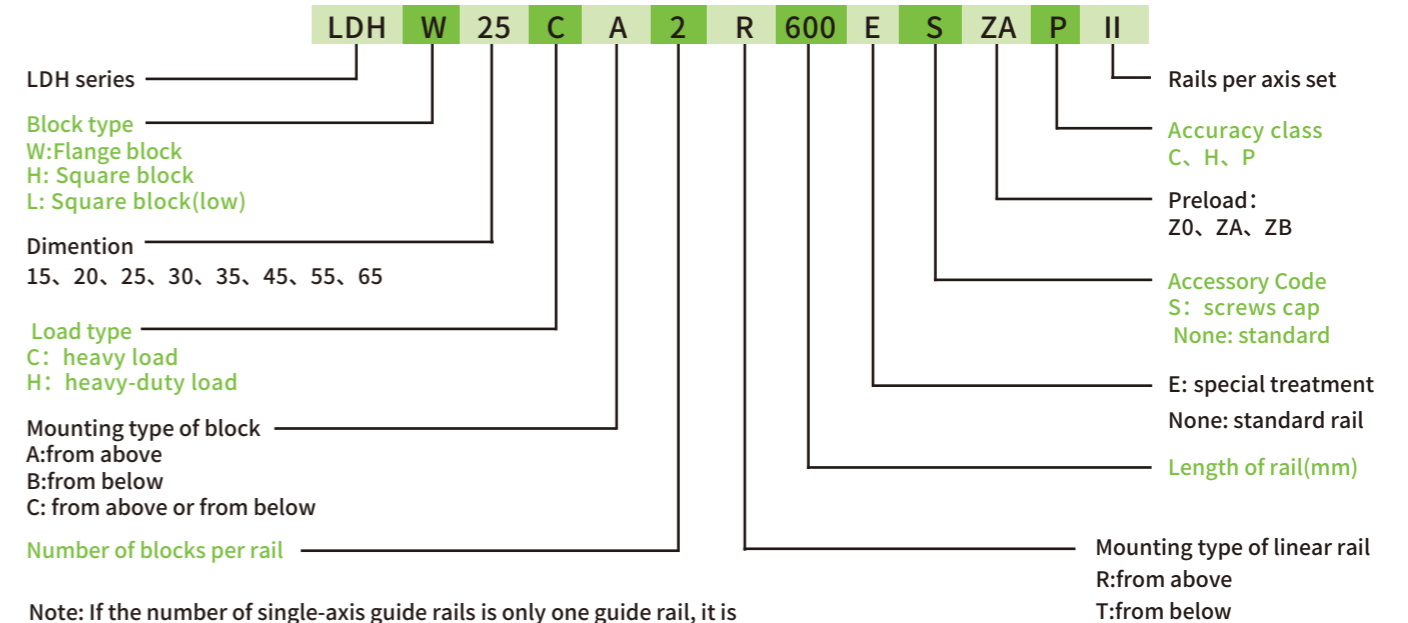

Interchangeable linear guide product model

Interchangeable type rail product model

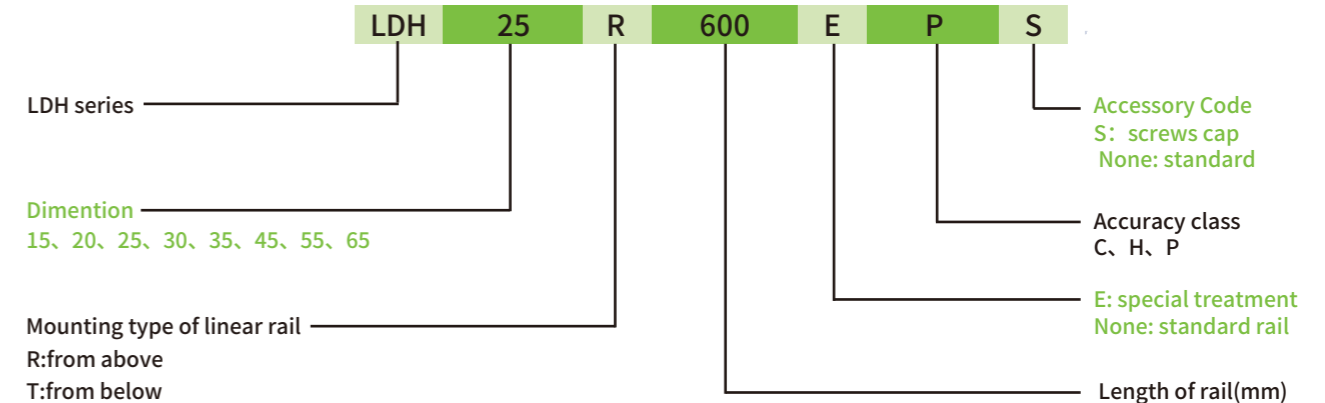

Interchangeable type block product model

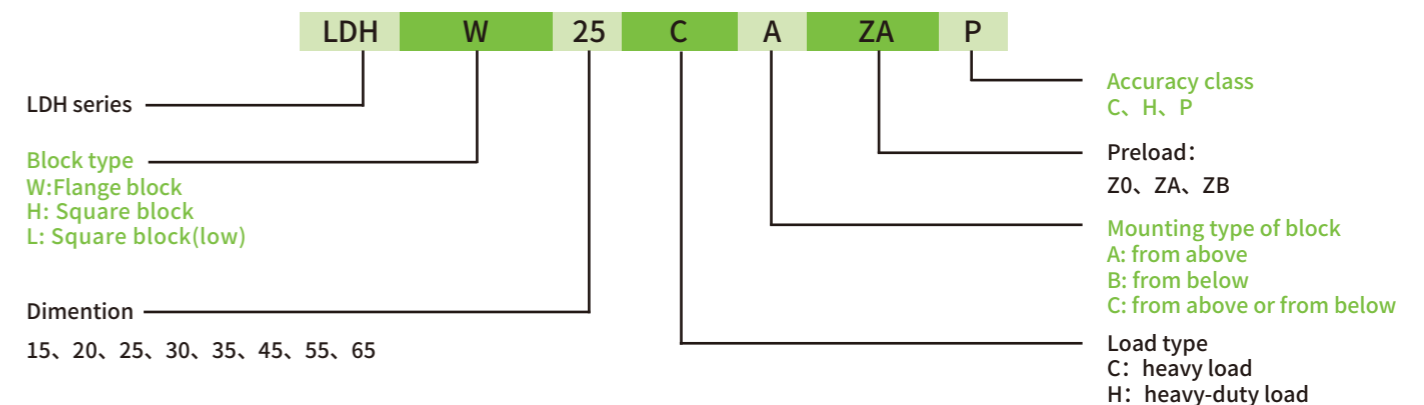

1 Block type

LTROBOT offers two types of linear guide: flange and square. The square linear guide is divided into H type and L type, and the L type is H type's low profile type linear guide. The combined height is the same as the flange type linear guide.

Type	Standard	Shape	Height dimension (mm)	Length of rail (mm)	Application equipment
Square block	LDHH-CA LDHH-HA		28 ↓ 90	100 ↓ 4000/6000	<ul style="list-style-type: none"> • Machining center • Machine tool • Precision processing machine • Heavy duty cutting machine
	LDHL-CA LDHL-HA		24 ↓ 70	100 ↓ 4000/6000	<ul style="list-style-type: none"> • Marble cutting machine • Grinder • Injection molding machine • Punch
Flange block	LDHW-CA LDHW-HA		24 ↓ 90	100 ↓ 4000/6000	<ul style="list-style-type: none"> • Automation Equipment • Measuring instrument • Woodworking and wood processing machines • 3D printer • Laser • Printing • Medical • Clothing equipment
	LDHW-CB LDHW-HB		24 ↓ 90	100 ↓ 4000/6000	
	LDHW-CC LDHW-HC		24 ↓ 90	100 ↓ 4000/6000	

2 Linear guide type

In addition to the general from above lock bolt holes, LTROBOT also provides a from below lock bolt hole guide for easy installation and use.

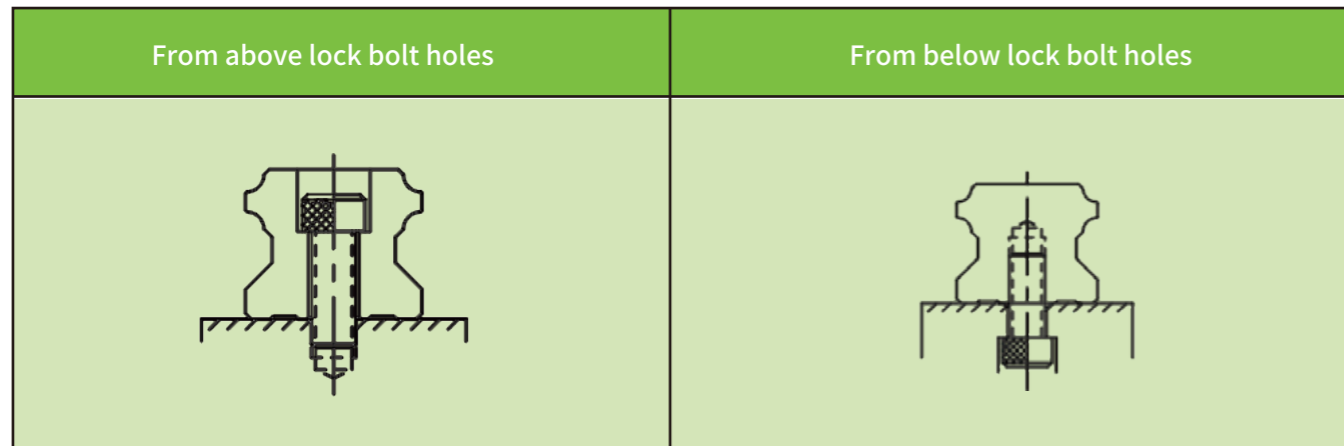

3 Accuracy class

The precision of LDH series linear guides is divided into five levels: ordinary, high, precision, ultra-precision and ultra-high precision(N H P SP UP). Customers can select the precision according to the precision requirements of the equipment.

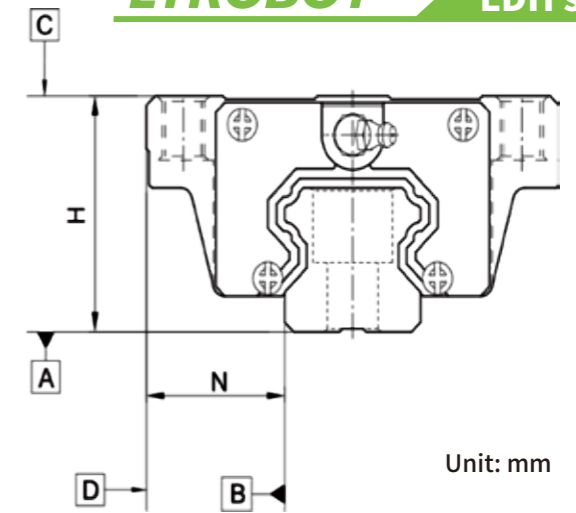

(1) Non-interchangeable linear guide accuracy

Assembly precision

Model	LDH-15,20				
Accuracy class	Normal (N)	Senior (H)	Precision (P)	High precision (SP)	Ultra precision
Allowable dimensional error of height H	±0.1	±0.03	0	0	0
Allowable size error of width N	±0.1	±0.03	0	0	0
Mutual error of pair height H	0.02	0.01	0.006	0.004	0.003
Mutual error of pairwise width N	0.02	0.01	0.006	0.004	0.003
The parallelism of the block C facing the A side of the guide rail	Running parallelism				
The parallelism of the block D facing the B side of the guide rail	Running parallelism				

Model	LDH-25,30,35				
Accuracy class	Normal (N)	Senior (H)	Precision (P)	High precision (SP)	Ultra precision
Allowable dimensional error of height H	±0.1	±0.04	0	0	0
Allowable size error of width N	±0.1	±0.04	0	0	0
Mutual error of pair height H	0.02	0.015	0.007	0.005	0.003
Mutual error of pairwise width N	0.03	0.015	0.007	0.005	0.003
The parallelism of the block C facing the A side of the guide rail	Running parallelism				
The parallelism of the block D facing the B side of the guide rail	Running parallelism				

Model	LDH-45, 55				
Accuracy class	Normal (N)	Senior (H)	Precision (P)	High precision (SP)	Ultra precision
Allowable dimensional error of height H	±0.1	±0.05	0	0	0
Allowable size error of width N	±0.1	±0.05	0	0	0
Mutual error of pair height H	0.03	0.015	0.007	0.005	0.003
Mutual error of pairwise width N	0.03	0.02	0.01	0.007	0.005
The parallelism of the block C facing the A side of the guide rail	Running parallelism				
The parallelism of the block D facing the B side of the guide rail	Running parallelism				

(2) Interchangeable linear guide accuracy

Interchangeable linear guide precision

Model	LDH-15, 20		
Accuracy class	Normal (N)	Senior (H)	Precision (P)
Allowable dimensional error of height H	±0.1	±0.03	±0.015
Allowable size error of width N	±0.1	±0.03	±0.015
Mutual error of pair height H	0.02	0.01	0.006
Mutual error of pairwise width N	0.02	0.01	0.006
The parallelism of the block C facing the A side of the guide rail	Running parallelism		
The parallelism of the block D facing the B side of the guide rail	Running parallelism		

Model	LDH-25,30,35		
Accuracy class	Normal (N)	Senior (H)	Precision (P)
Allowable dimensional error of height H	±0.1	±0.04	±0.02
Allowable size error of width N	±0.1	±0.04	±0.02
Mutual error of pair height H	0.02	0.015	0.007
Mutual error of pairwise width N	0.03	0.015	0.007
The parallelism of the block C facing the A side of the guide rail	Running parallelism		
The parallelism of the block D facing the B side of the guide rail	Running parallelism		

Model	LDH-45,55		
Accuracy class	Normal (N)	Senior (H)	Precision (P)
Allowable dimensional error of height H	±0.1	±0.05	±0.025
Allowable size error of width N	±0.1	±0.05	±0.025
Mutual error of pair height H	0.03	0.015	0.007
Mutual error of pairwise width N	0.03	0.02	0.01
The parallelism of the block C facing the A side of the guide rail	Running parallelism		
The parallelism of the block D facing the B side of the guide rail	Running parallelism		

Running parallelism

(3) Running parallelism

Length of rail (mm)	Accuracy class(μm)				
	C	H	P	SP	UP
~100	12	7	3	2	2
100~200	14	9	4	2	2
200~300	15	10	5	3	2
300~500	17	12	6	3	2
500~700	20	13	7	4	2
700~900	22	15	8	5	3
900~1100	24	16	9	6	3
1100~1500	26	18	11	7	4
1500~1900	28	20	13	8	4
1900~2500	31	22	15	10	5
2500~3100	33	25	18	11	6
3100~3600	36	27	20	14	7
3600~4000	37	28	21	15	7

Preload

(1) Definition of preload

The preload is to pre-send the load force of the steel ball, that is, increase the diameter of the steel ball, and use the negative gap between the steel ball and the steel ball track to pre-press, which can improve the rigidity of the linear guide and eliminate the gap; The pressure increases the rigidity of the linear guide. However, the small size is recommended to use the preload under the light preload to avoid the excessive use of preload to reduce its service life.

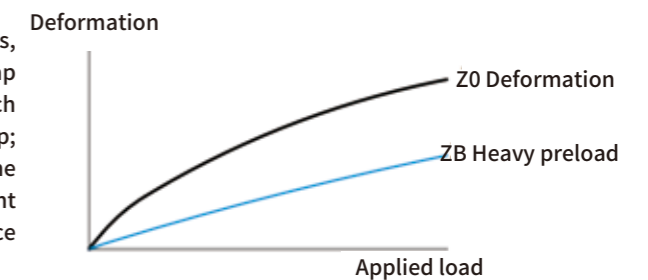

(2) Level of preload

The LTROBOT series linear guide are available in three standard preloads to select the appropriate preload according to the application.

Level of preload	Mark	Preload	Conditions of Use	Application of Scope
No preload	Z0	0-0.02C	Fixed load direction with low impact and low precision	Transfer device, automatic packaging machine, automation industrial machinery, XY axis for general industrial machinery, welding machine, fuse machine, tool changer
Middle preload	ZA	0.05C-0.07C	Light load and high precision	General industrial machinery Z-axis, electric discharge machine, NC machine tool, precision XY platform, measuring device, machining center, vertical machining center, industrial robot, automatic coating machine, various high-speed material supply devices
Heavy preload	ZB	0.10C-0.12C	Requirements for rigidity, vibration and impact	Machining center, grinding machine, NC lathe, vertical or horizontal milling machine, machine tool Z axis, heavy cutting machine
Level	Interchangeable linear guide		Non-interchangeable track (assembly)	
Level of preload	Z0,ZA		Z0,ZA,ZB	

Note: preload C is dynamic load capacity

LDH series linear guide dimension table

○ LDHH-CA / LDHH-HA

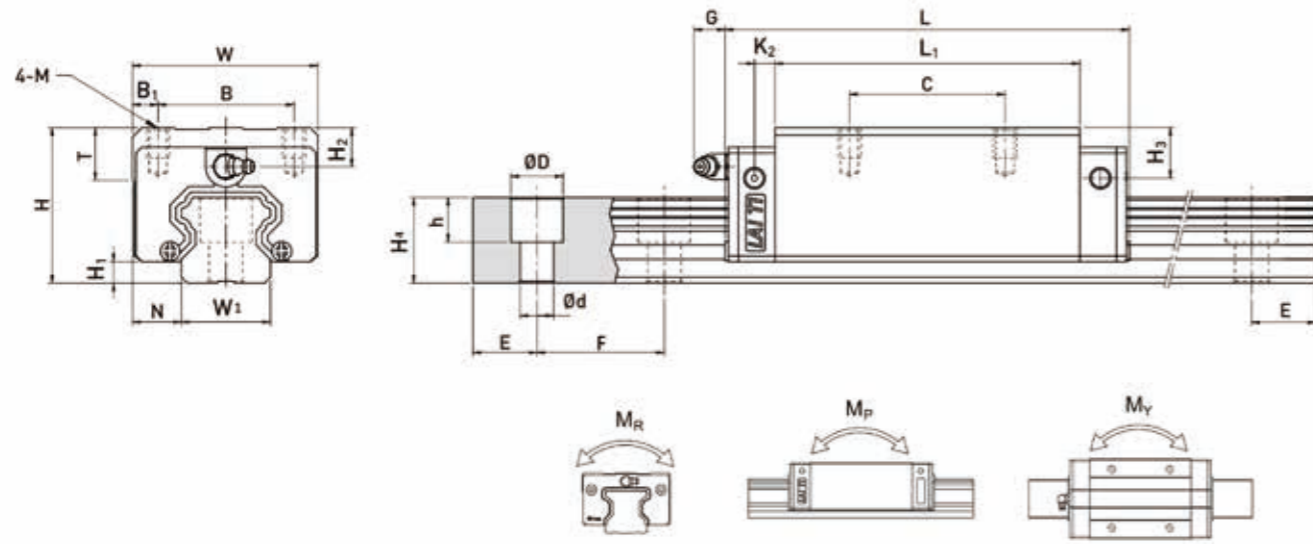

LDH series linear guide dimension table

○ LDHL-CA / LDHL-HA

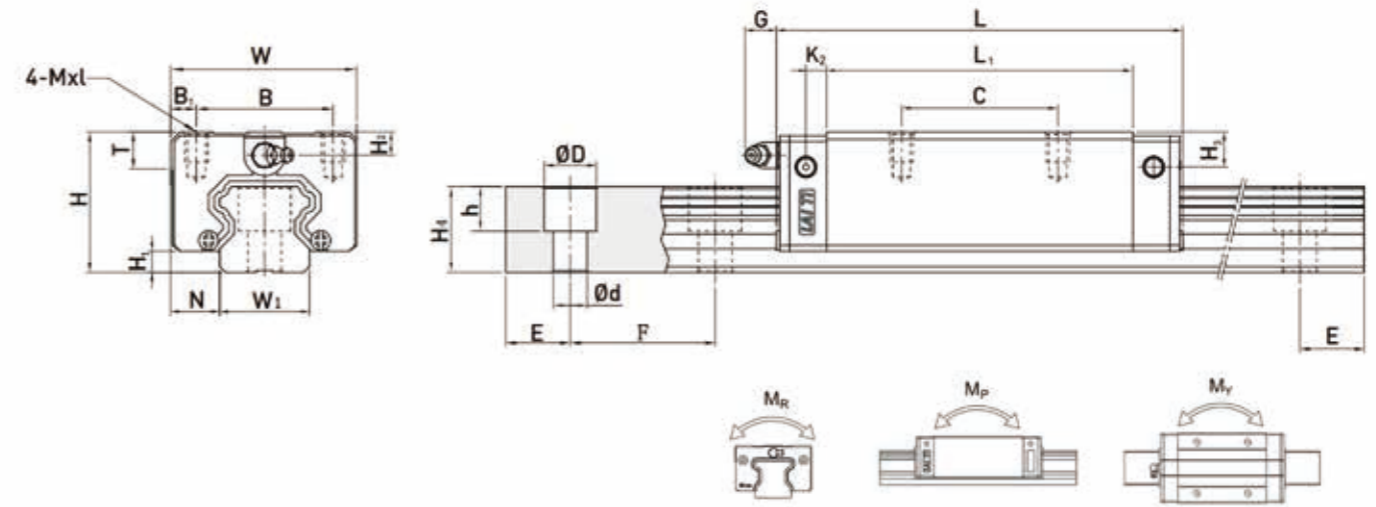

Linear Guide parameter

Note: 1kgf=9.81N

Model	Assembly dimension (mm)		Block dimension (mm)																	Rail dimension (mm)										Size of fixed bolts for sliding rails (mm)	Basic dynamic load capacity C _{dyn} (kN)	Basic static load capacity C ₀ (kN)	Static permissible moment			Weight	
	H	H ₁	N	W	B	B ₁	C	L ₁	L	K ₂	G	MxL	T	H ₂	H ₃	W ₁	H ₄	D	h	d	F	E	M _R	M _P	M _Y	Block	Rail										
																												KN-m	KN-m	KN-m	kg	kg/m					
LDHH15CA	28	4.3	9.5	34	26	4	26	39.4	61.4	4.85	5.3	M4X5	6	7.95	7.7	15	15	7.5	5.3	4.5	60	20	M4X16	11.38	16.97	0.12	0.10	0.10	0.18	1.45							
LDHH20CA	30	4.6	12	44	32	6	36	50.5	77.5	6	12	M5X6	8	6	6	20	17.5	9.5	8.5	6	60	20	M5X16	17.75	27.76	0.27	0.20	0.20	0.30	2.21							
LDHH20HA							50	65.2	92.2															21.18	35.90	0.35	0.35	0.35	0.39								
LDHH25CA	40	5.5	12.5	48	35	6.5	35	58	84	6	12	M6X8	8	10	9	23	22	11	9	7	60	20	M6X20	26.48	36.49	0.42	0.33	0.33	0.51	3.21							
LDHH25HA							50	78.6	104.6															32.75	49.44	0.56	0.57	0.57	0.69								
LDHH30CA	45	6	16	60	40	10	40	70	97.4	6	12	M8X10	8.5	9.5	13.8	28	26	14	12	9	80	20	M8X25	38.74	52.19	0.66	0.53	0.53	0.88	4.47							
LDHH30HA							60	93	120.4															47.27	69.16	0.88	0.92	0.92	1.16								
LDHH35CA	55	7.5	18	70	50	10	50	80	112.4	7	12	M8X12	10.2	16	19.6	34	29	14	12	9	80	20	M8X25	49.52	69.16	1.16	0.81	0.81	1.45	6.30							
LDHH35HA							72	105.8	138.2															60.21	91.63	1.54	1.40	1.40	1.92								
LDHH45CA	70	9.5	20.5	86	60	13	60	97	139.4	10	12.9	M10X17	16	18.5	30.5	45	38	20	17	14	105	22.5	M12X35	77.57	102.71	1.98	1.55	1.55	2.73	10.41							
LDHH45HA							80	128.8	171.2															94.54	136.46	2.63	2.68	2.68	3.61								
LDHH55CA	80	13	23.5	100	75	12.5	75	117.7	166.7	11	12.9	M12X18	17.5	22	29	53	44	23	20	16	120	30	M14X45	114.44	148.33	3.69	2.64	2.64	4.17	15.08							
LDHH55HA							95	155.8	204.8															139.35	196.20	4.88	4.57	4.57	5.49								
LDHH65CA	90	15	31.5	126	76	25	70	144.2	200.2	14	12.9	M16X20	25	15	15	63	53	26	22	18	150	35	M16X50	163.63	215.33	6.65	4.27	4.27	7.00	21.18							
LDHH65HA							120	203.6	259.6															208.36	303.13	9.38	7.38	7.38	9.82								

Linear Guide parameter

Note: 1kgf=9.81N

Model	Assembly dimension (mm)		Block dimension (mm)																	Rail dimension (mm)										Size of fixed bolts for sliding rails (mm)	Basic dynamic load capacity C _{dyn} (kN)	Basic static load capacity C ₀ (kN)	Static permissible moment			Weight	
	H	H ₁	N	W	B	B ₁	C	L ₁	L	K ₂	G	MxL	T	H ₂	H ₃	W ₁	H ₄	D	h	d	F	E	M _R	M _P	M _Y	Block	Rail										
																												KN-m	KN-m	KN-m	kg	kg/m					
LDHL15CA	24	4.3	9.5	34	26	4	26	39.4	61.4	4.85	5.3	M4X4	2	3.95	3.7	15	15	7.5	5.3	4.5	60	20	M4X16	11.38	16.97	0.12	0.10	0.10	0.14	1.45							
LDHL25CA	36	5.5	12.5	48	35	6.5	35	58	84	6	12	M6X6	4	6	9	23	22	11	9	7	60	20	M6X20	26.48	36.49	0.42	0.33	0.33	0.42	3.21							
LDHL25HA							50	78.6	104.6															32.75	49.44	0.56	0.57	0.57	0.57								
LDHL30CA	42	6	16	60	40	10	40	70	97.4	6	12	M8X10	4.5	6.5	10.8	28	26	14	12	9	80	20	M8X25	38.74	52.19	0.66	0.53	0.53	0.78	4.47							
LDHL30HA							60	93	120.4															47.27	69.16	0.88	0.92	0.92	1.03								
LDHL35CA	48	7.5	18	70	50	10	50	80	112.4	7	12	M8X12	6.2	9	12.6	34	29	14	12	9	80	20	M8X25	49.52	69.16	1.16	0.81	0.81	1.14	6.3							
LDHL35HA							72	105.8	138.2															60.21	91.63	1.54	1.40	1.40	1.52								
LDHL45CA	60	9.5	20.5	86	60	13	60	97	139.4	10	12.9	M10X17	12	8.5	20.5	45	38	20	17	14	105	22.5	M12X35	77.57	102.71	1.98	1.55	1.55	2.08	10.41							
LDHL45HA							80	128.8	171.2															94.54	136.46	2.63	2.68	2.68	2.75								
LDHL55CA	70	13	23.5	100	75	12.5	75	117.7	166.7	11	12.9	M12X18	13.5	12	19	53	44	23	20	16	120	30	M14X45	114.44	148.33	3.69	2.64	2.64	3.25	15.08							
LDHL55HA							95	155.8	204.8															139.35	196.20	4.88	4.57	4.57	4.27								

LDH series linear guide dimension table

○ LDHW-CA / LDHW-HA

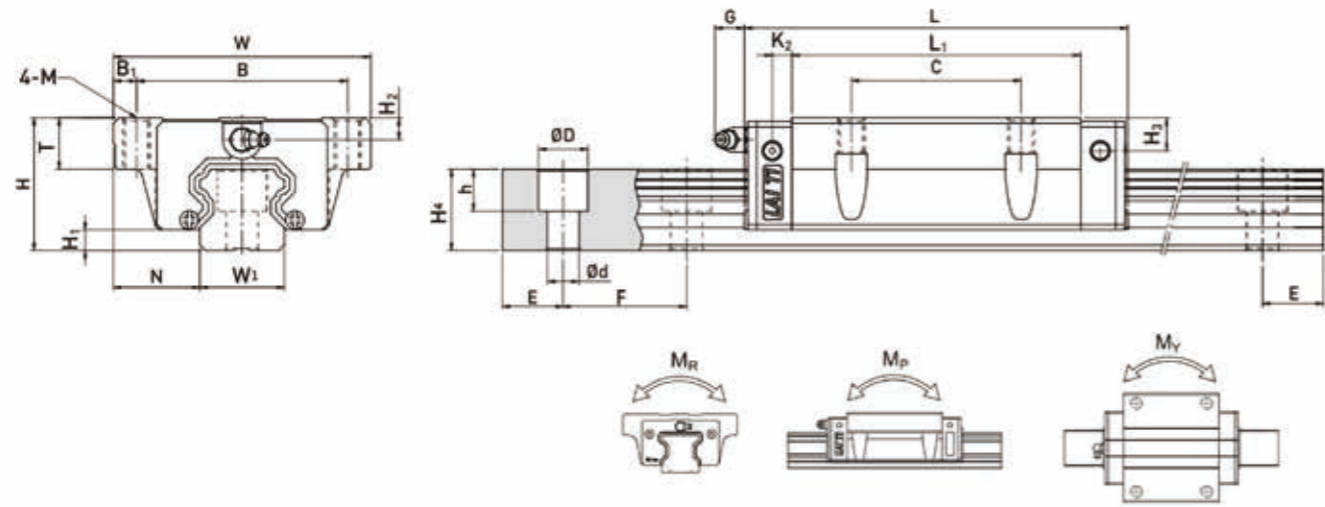

Linear Guide parameter

Note: 1kgf=9.81N

Model	Assembly dimension (mm)		Block dimension (mm)													Rail dimension (mm)						Size of fixed bolts for sliding rails (mm)	Basic dynamic load capacity C _{0yn} (kN)	Basic static load capacity C ₀ (kN)	Static permissible moment			Weight		
	H	H ₁	N	W	B	B ₁	C	L ₁	L	k ₂	G	M	T	H ₂	H ₃	W ₁	H ₄	D	h	d	F				E	M _R	M _P	M _Y	Block	Rail
																									KN-m	KN-m	KN-m	kg	kg/m	
LDHW15CA	24	4.3	16	47	38	4.5	30	39.4	61.4	4.85	5.3	M5	8.9	3.95	3.7	15	15	7.5	5.3	4.5	60	20	M4X16	11.38	16.97	0.12	0.10	0.10	0.17	1.45
LDHW20CA	30	4.6	21.5	63	53	5	40	50.5	77.5	6	12	M6	10	6	6	20	17.5	9.5	8.5	6	60	20	M5X16	17.75	27.76	0.27	0.20	0.20	0.40	2.21
LDHW20HA								65.2	92.2															21.18	35.90	0.35	0.35	0.35	0.52	
LDHW25CA	36	5.5	23.5	70	57	6.5	45	58	84	6	12	M8	14	6	5	23	22	11	9	7	60	20	M6X20	26.48	36.49	0.42	0.33	0.33	0.59	3.21
LDHW25HA								78.6	104.6															32.75	49.44	0.56	0.57	0.57	0.80	
LDHW30CA	42	6	31	90	72	9	52	70	97.4	6	12	M10	16	6.5	10.8	28	26	14	12	9	80	20	M8X25	38.74	52.19	0.66	0.53	0.53	1.09	4.47
LDHW30HA								93	120.4															47.27	69.16	0.88	0.92	0.92	1.44	
LDHW35CA	48	7.5	33	100	82	9	62	80	112.4	7	12	M10	18	9	12.6	34	29	14	12	9	80	20	M8X25	49.52	69.16	1.16	0.81	0.81	1.56	6.30
LDHW35HA								105.8	138.2															60.21	91.63	1.54	1.40	1.40	2.06	
LDHW45CA	60	9.5	37.5	120	100	10	80	97	139.4	10	12.9	M12	22	8.5	20.5	45	38	20	17	14	105	22.5	M12X35	77.57	102.71	1.98	1.55	1.55	2.79	10.41
LDHW45HA								128.8	171.2															94.54	136.46	2.63	2.68	2.68	3.69	
LDHW55CA	70	13	43.5	140	116	12	95	117.7	166.7	11	12.9	M14	26.5	12	19	53	44	23	20	16	120	30	M14X45	114.44	148.33	3.69	2.64	2.64	4.52	15.08
LDHW55HA								155.8	204.8															139.35	196.20	4.88	4.57	4.57	5.96	
LDHW65CA	90	15	53.5	170	142	14	110	144.2	200.2	14	12.9	M16	37.5	15	15	63	53	26	22	18	150	35	M16X50	163.63	215.33	6.65	4.27	4.27	9.17	21.18
LDHW65HA								203.6	259.6															208.36	303.13	9.38	7.38	7.38	12.89	

LDH series linear guide dimension table

○ LDHW-CB / LDHW-HB

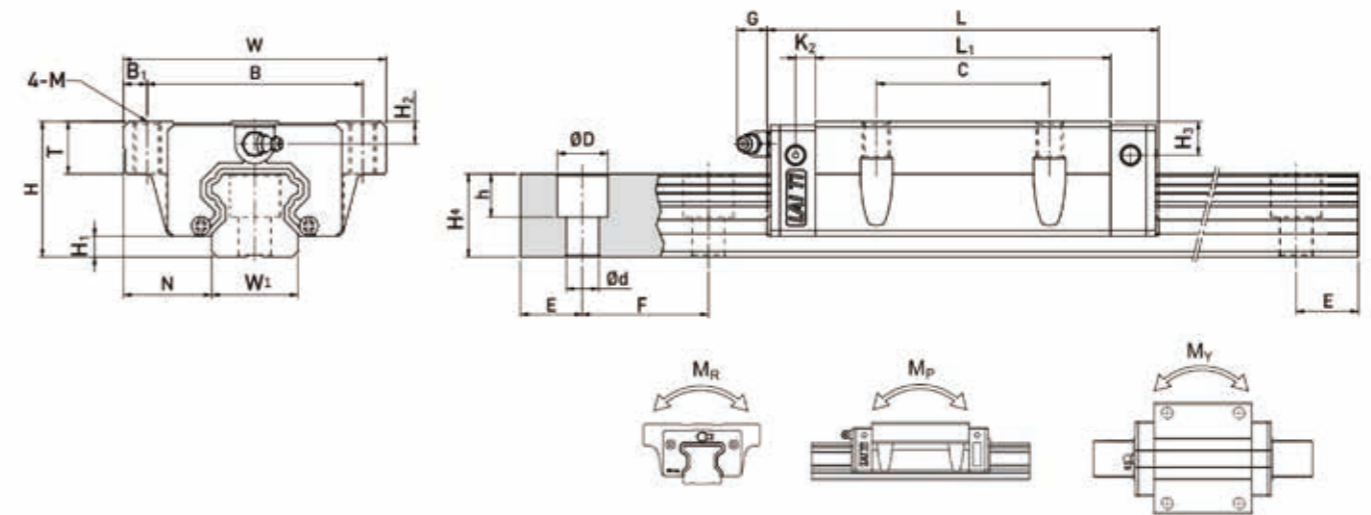

Linear Guide parameter

Note: 1kgf=9.81N

Model	Assembly dimension (mm)		Block dimension (mm)													Rail dimension (mm)						Size of fixed bolts for sliding rails (mm)	Basic dynamic load capacity C _{0yn} (kN)	Basic static load capacity C ₀ (kN)	Static permissible moment			Weight		
	H	H ₁	N	W	B	B ₁	C	L ₁	L	k ₂	G	M	T	H ₂	H ₃	W ₁	H ₄	D	h	d	F				E	M _R	M _P	M _Y	Block	Rail
																									KN-m	KN-m	KN-m	kg	kg/m	
LDHW15CB	24	4.3	16	47	38	4.5	30	39.4	61.4	4.85	5.3	4.5	8.9	3.95	3.7	15	15	7.5	5.3	4.5	60	20	M4X16	11.38	16.97	0.12	0.10	0.10	0.17	1.45
LDHW20CB	30	4.6	21.5	63	53	5	40	50.5	77.5	6	12	6	10	6	6	20	17.5	9.5	8.5	6	60	20	M5X16	17.75	27.76	0.27	0.20	0.20	0.40	2.21
LDHW20HB								65.2	92.2															21.18	35.90	0.35	0.35	0.35	0.52	
LDHW25CB	36	5.5	23.5	70	57	6.5	45	58	84	6	12	7	14	6	5	23	22	11	9	7	60	20	M6X20	26.48	36.49	0.42	0.33	0.33	0.59	3.21
LDHW25HB								78.6	104.6															32.75	49.44	0.56	0.57	0.57	0.80	
LDHW30CB	42	6	31	90	72	9	52	70	97.4	6	12	9	16	6.5	10.8	28	26	14	12	9	80	20	M8X25	38.74	52.19	0.66	0.53	0.53	1.09	4.47
LDHW30HB								93	120.4															47.27	69.16	0.88	0.92	0.92	1.44	
LDHW35CB	48	7.5	33	100	82	9	62	80	112.4	7	12	9	18	9	12.6	34	29	14	12	9	80	20	M8X25	49.52	69.16	1.16	0.81	0.81	1.56	6.30
LDHW35HB								105.8	138.2															60.21	91.63	1.54	1.40	1.40	2.06	
LDHW45CB	60	9.5	37.5	120	100	10	80	97	139.4	10	12.9	11	22	8.5	20.5	45	38	20	17	14	105	22.5	M12X35	77.57	102.71	1.98	1.55	1.55	2.79	10.41
LDHW45HB								128.8	171.2															94.54	136.46	2.63	2.68	2.68	3.69	
LDHW55CB	70	13	43.5	140	116	12	95	117.7	166.7	11	12.9	14	26.5	12	19	53	44	23	20	16	120	30	M14X45	114.44	148.33	3.69	2.64	2.64	4.52	15.08
LDHW55HB								155.8	204.8															139.35	196.20	4.88	4.57	4.57	5.96	
LDHW65CB	90	15	53.5	170	142	14	110	144.2	200.2	14	12.9	16	37.5	15	15	63	53	26	22	18	150	35	M16X50	163.63	215.33	6.65	4.27	4.27	9.17	21.18
LDHW65HB								203.6	259.6															208.36	303.13	9.38	7.38	7.38	12.89	

LDH series linear guide dimension table

○ LDHW-CC / LDHW-HC

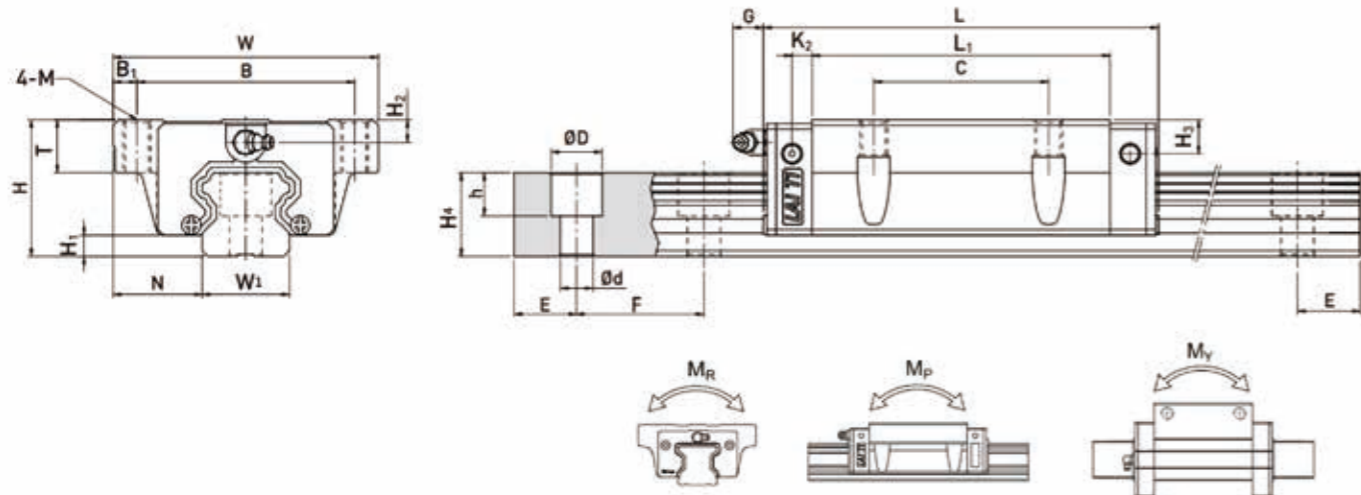

Note: 1kgf=9.81N

Linear Guide parameter

Model	Assembly dimension (mm)		Block dimension (mm)													Rail dimension (mm)										Size of fixed bolts for sliding rails (mm)	Basic dynamic load capacity C _{0m} (kN)	Basic static load capacity C ₀ (kN)	Static permissible moment			Block kg	Rail kg/m	Weight
	H	H ₁	N	W	B	B ₁	C	L ₁	L	k ₂	G	M	T	H ₂	H ₃	W ₁	H ₄	D	h	d	F	E	M _R KN-m	M _p KN-m	M _y KN-m									
LDHW15CC	24	4.3	16	47	38	4.5	30	39.4	61.4	4.85	5.3	M5	8.9	3.95	3.7	15	15	7.5	5.3	4.5	60	20	M4X16	11.38	16.97	0.12	0.10	0.10	0.17	1.45				
LDHW20CC	30	4.6	21.5	63	53	5	40	50.5	77.5	6	12	M6	10	6	6	20	17.5	9.5	8.5	6	60	20	M5X16	17.75	27.76	0.27	0.20	0.20	0.40	2.21				
LDHW20HC								65.2	92.2															21.18	35.90	0.35	0.35	0.35	0.52					
LDHW25CC	36	5.5	23.5	70	57	6.5	45	58	84	6	12	M8	14	6	5	23	22	11	9	7	60	20	M6X20	26.48	36.49	0.42	0.33	0.33	0.59	3.21				
LDHW25HC								78.6	104.6															32.75	49.44	0.56	0.57	0.57	0.80					
LDHW30CC	42	6	31	90	72	9	52	70	97.4	6	12	M10	16	6.5	10.8	28	26	14	12	9	80	20	M8X25	38.74	52.19	0.66	0.53	0.53	1.09	4.47				
LDHW30HC								93	120.4															47.27	69.16	0.88	0.92	0.92	1.44					
LDHW35CC	48	7.5	33	100	82	9	62	80	112.4	7	12	M10	18	9	12.6	34	29	14	12	9	80	20	M8X25	49.52	69.16	1.16	0.81	0.81	1.56	6.30				
LDHW35HC								105.8	138.2															60.21	91.63	1.54	1.40	1.40	2.06					
LDHW45CC	60	9.5	37.5	120	100	10	80	97	139.4	10	12.9	M12	22	8.5	20.5	45	38	20	17	14	105	22.5	M12X35	77.57	102.71	1.98	1.55	1.55	2.79	10.41				
LDHW45HC								128.8	171.2															94.54	136.46	2.63	2.68	2.68	3.69					
LDHW55CC	70	13	43.5	140	116	12	95	117.7	166.7	11	12.9	M14	26.5	12	19	53	44	23	20	16	120	30	M14X45	114.44	148.33	3.69	2.64	2.64	4.52	15.08				
LDHW55HC								155.8	204.8															139.35	196.20	4.88	4.57	4.57	5.96					
LDHW65CC	90	15	53.5	170	142	14	110	144.2	200.2	14	12.9	M16	37.5	15	15	63	53	26	22	18	150	35	M16X50	163.63	215.33	6.65	4.27	4.27	9.17	21.18				
LDHW65HC								203.6	259.6															208.36	303.13	9.38	7.38	7.38	12.89					

1-2-2 Non-interchangeable linear guide product model

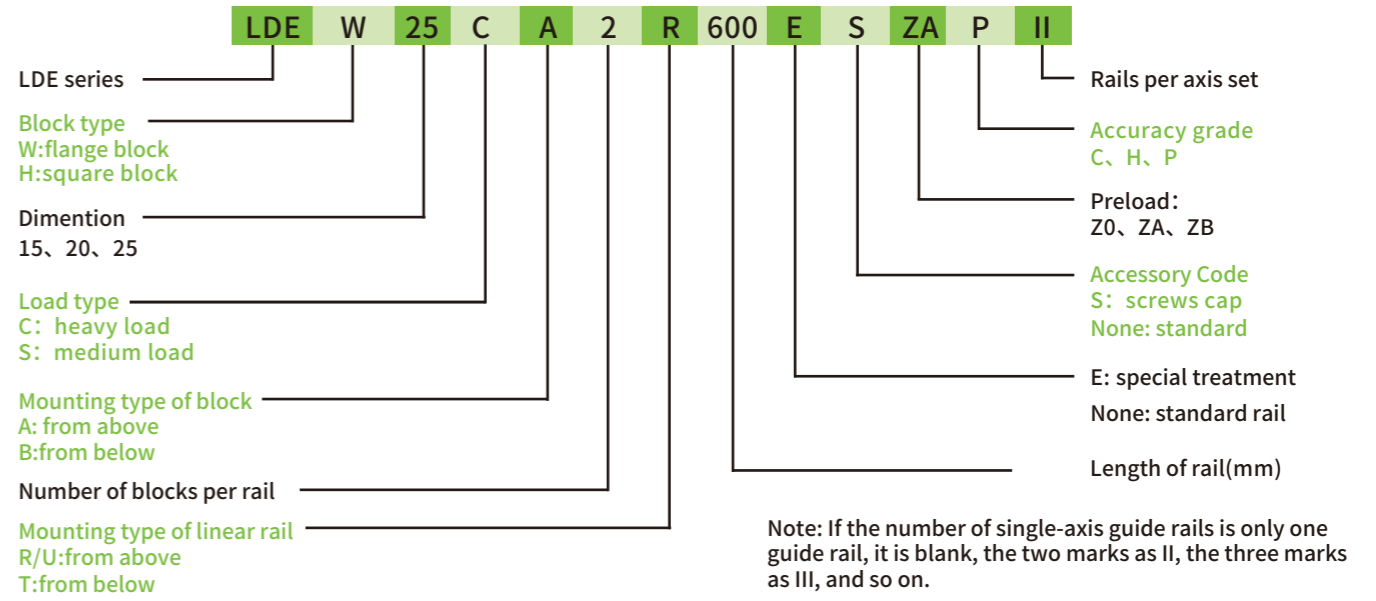

Note: If the number of single-axis guide rails is only one guide rail, it is blank, the two marks as II, the three marks as III, and so on.

Interchangeable linear guide product model

Interchangeable type rail product model

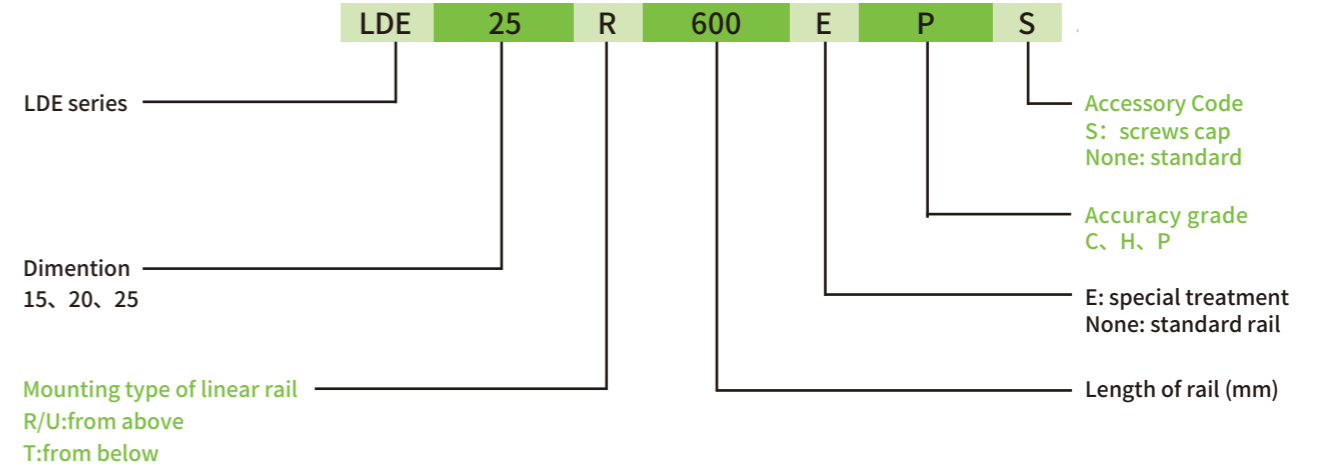

Interchangeable type block product model

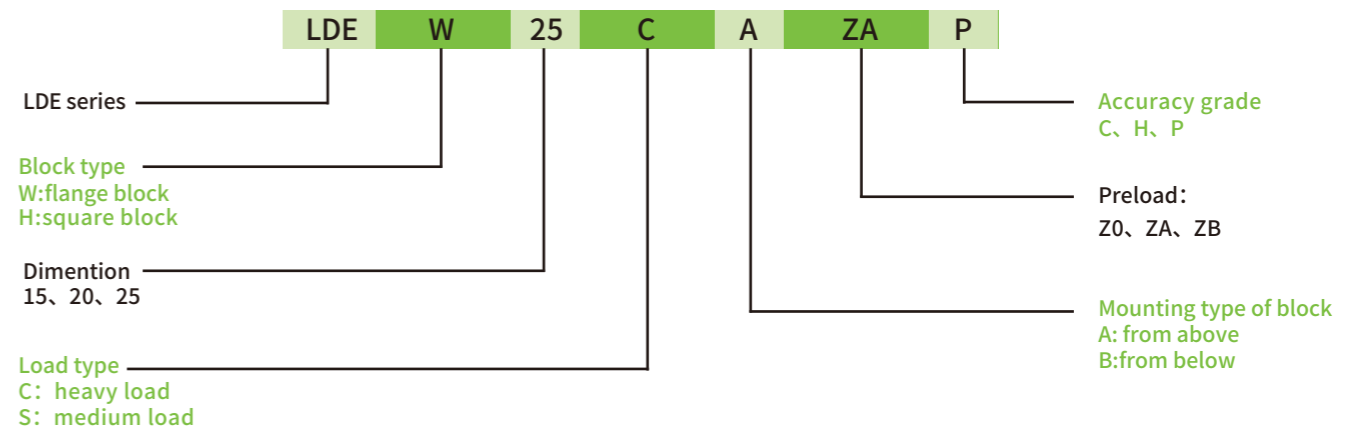

1 Block type

LTROBOT offers two types of blocks: flange and square

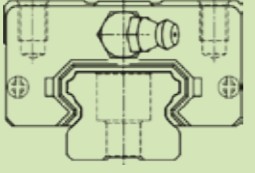
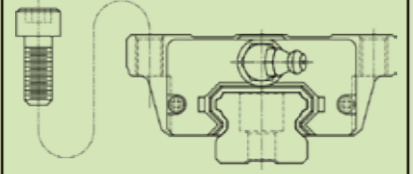
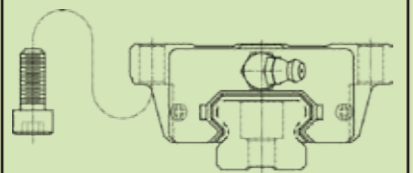
Type	Standard	Shape	Height dimension (mm)	Length of rail (mm)	Application equipment
Square block	LDEH-SA LDEH-CA		24	100	<ul style="list-style-type: none"> • Machining center • Machine tool • Precision processing machine • Heavy duty cutting machine • Marble cutting machine
			↓	↓	
Flange block	LDEW-SA LDEW-CA		24	100	<ul style="list-style-type: none"> • Grinder • Injection molding machine • Punch • Automation Equipment • Measuring instrument • Woodworking and wood processing machines • 3D printer • Laser • Printing • Medical • Clothing equipment
			↓	↓	
Flange block	LDEW-SB LDEW-CB		24	100	
			↓	↓	

2 Linear guide type

In addition to the general from above lock bolt holes, LTROBOT also provides a from below lock bolt hole guide for easy installation and use.



3 Accuracy class

The precision of LDE series linear guides is divided into five levels: ordinary, high, precision, ultra-precision and ultra-high precision(N H P SP UP). Customers can select the precision according to the precision requirements of the equipment.

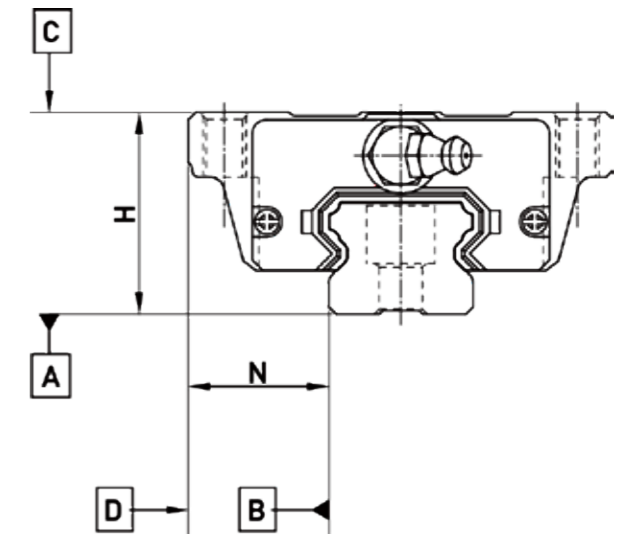

(1) Non-interchangeable linear guide accuracy

Assembly precision

Model	LDE-15,20				
	Accuracy class	Normal (N)	Senior (H)	Precision (P)	High precision (SP)
Allowable dimensional error of height H	±0.1	±0.03	0	0	0
Allowable size error of width N	±0.1	±0.03	0	0	0
Mutual error of pair height H	0.02	0.01	0.006	0.004	0.003
Mutual error of pairwise width N	0.02	0.01	0.006	0.004	0.003
The parallelism of the block C facing the A side of the guide rail	Running parallelism				
The parallelism of the block D facing the B side of the guide rail	Running parallelism				

Assembly precision

Model	LDE-25,30				
	Accuracy class	Normal (N)	Senior (H)	Precision (P)	High precision (SP)
Allowable dimensional error of height H	±0.1	±0.04	0	0	0
Allowable size error of width N	±0.1	±0.04	0	0	0
Mutual error of pair height H	0.02	0.015	0.007	0.005	0.003
Mutual error of pairwise width N	0.03	0.015	0.007	0.005	0.003
The parallelism of the block C facing the A side of the guide rail	Running parallelism				
The parallelism of the block D facing the B side of the guide rail	Running parallelism				

(2) Interchangeable linear guide accuracy

Interchangeable linear guide precision

Model	LDE15,20		
Accuracy class	Normal (N)	Senior (H)	Precision (P)
Allowable dimensional error of height H	±0.1	±0.03	±0.015
Allowable size error of width N	±0.1	±0.03	±0.015
Mutual error of pair height H	0.02	0.01	0.006
Mutual error of pairwise width N	0.02	0.01	0.006
The parallelism of the block C facing the A side of the guide rail	Running parallelism		
The parallelism of the block D facing the B side of the guide rail	Running parallelism		

Interchangeable linear guide precision

Model	LDE-25,30		
Accuracy class	Normal (N)	Senior (H)	Precision (P)
Allowable dimensional error of height H	±0.1	±0.04	±0.02
Allowable size error of width N	±0.1	±0.04	±0.02
Mutual error of pair height H	0.02	0.015	0.007
Mutual error of pairwise width N	0.03	0.015	0.007
The parallelism of the block C facing the A side of the guide rail	Running parallelism		
The parallelism of the block D facing the B side of the guide rail	Running parallelism		

Running parallelism

(3)Running parallelism

Length of rail (mm)	Accuracy class(μm)				
	C	H	P	SP	UP
~100	12	7	3	2	2
100~200	14	9	4	2	2
200~300	15	10	5	3	2
300~500	17	12	6	3	2
500~700	20	13	7	4	2
700~900	22	15	8	5	3
900~1100	24	16	9	6	3
1100~1500	26	18	11	7	4
1500~1900	28	20	13	8	4
1900~2500	31	22	15	10	5
2500~3100	33	25	18	11	6
3100~3600	36	27	20	14	7
3600~4000	37	28	21	15	7

Preload

(1) Definition of preload

The preload is to pre-send the load force of the steel ball, that is, increase the diameter of the steel ball, and use the negative gap between the steel ball and the steel ball track to pre-press, which can improve the rigidity of the linear guide and eliminate the gap; The pressure increases the rigidity of the linear guide. However, the small size is recommended to use the preload under the light preload to avoid the excessive use of preload to reduce its service life.

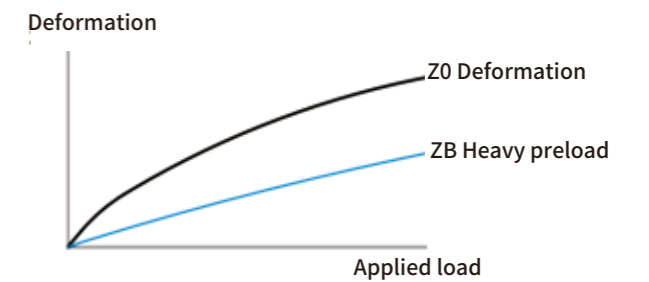

(2)Level of preload

The LTROBOT series linear guide are available in three standard preloads to select the appropriate preload according to the application.

Level of preload	Mark	Preload	Conditions of Use	Application of Scope
No preload	Z0	0-0.02C	Fixed load direction with low impact and low precision	Transfer device, automatic packaging machine, automation industrial machinery, XY axis for general industrial machinery, welding machine, fuse machine, tool changer
Middle preload	ZA	0.03C-0.05C	Light load and high precision	General industrial machinery Z-axis, electric discharge machine, NC machine tool, precision XY platform, measuring device, machining center, vertical machining center, industrial robot, automatic coating machine, various high-speed material supply devices
Heavy preload	ZB	0.06C-0.08C	Requirements for rigidity, vibration and impact	Machining center, grinding machine, NC lathe, vertical or horizontal milling machine, machine tool Z axis, heavy cutting machine
Level	Interchangeable linear guide		Non-interchangeable track (assembly)	
Level of preload	Z0,ZA		Z0,ZA, ZB	

Note: preload C is dynamic load capacity

LDE series linear guide dimension table

○ LDEH-SA/LDEH-CA

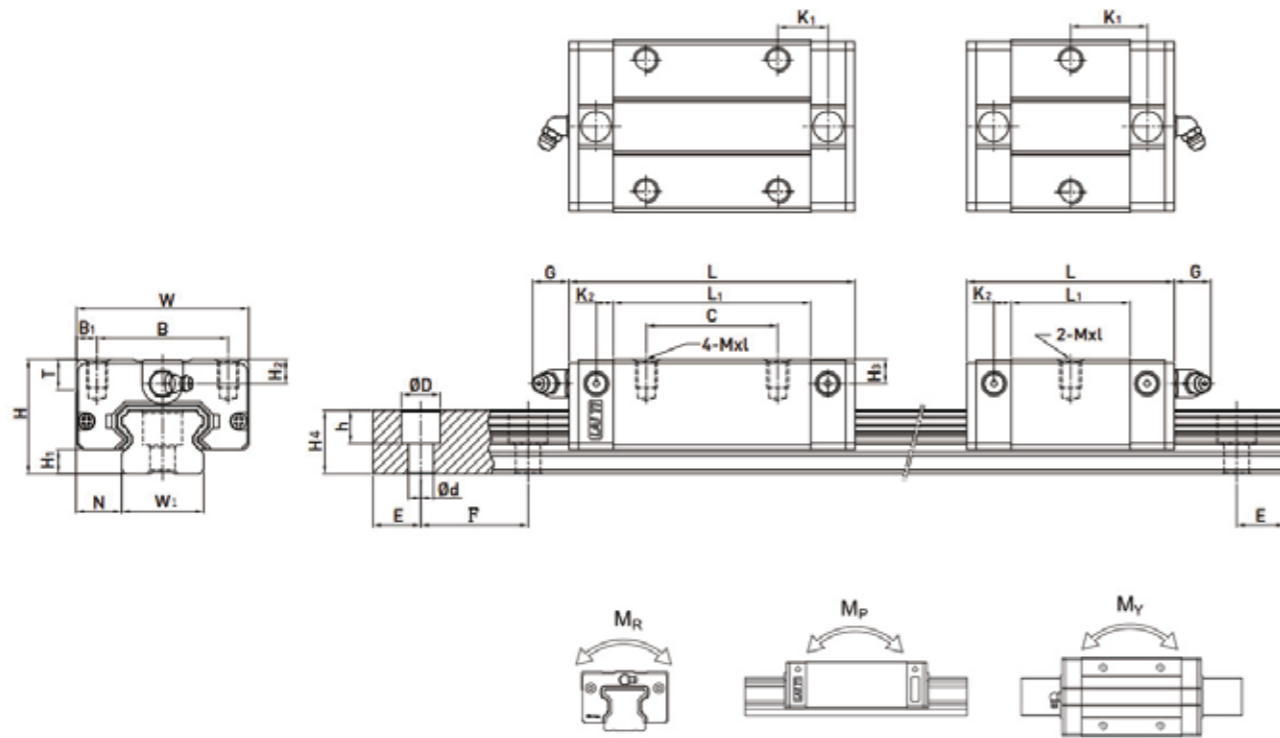

Linear Guide parameter

Note: 1kgf=9.81N

Model	Assembly dimension (mm)		Block dimension (mm)														Rail dimension (mm)										Size of fixed bolts for sliding rails (mm)	Basic dynamic load capacity C _{dyn} (kN)	Basic static load capacity C ₀ (kN)	Static permissible moment			Weight	
	H	H ₁	N	W	B	B ₁	C	L ₁	L	k ₁	k ₂	G	MxL	T	H ₂	H ₃	W ₁	H ₄	D	h	d	F	E	M _R	M _P	M _Y				Block	Rail			
																									KN-m	KN-m				KN-m	kg	kg/m		
LDEH15SA	24	4.5	9.5	34	26	4	-	23.1	40.1	14.8	-	-	-	-	-	-	-	-	-	-	-	-	-	-	-	-	5.35	9.40	0.08	0.04	0.04	0.09	1.25	
LDEH15CA							26	39.8	56.8	10.15	3.5	5.7	M4X6	6	5.5	6	15	12.5	6	4.5	3.5	60	20	M3X16		7.83	16.19	0.13	0.10	0.10	0.15			
LDEH20SA	28	6	11	42	32	5	-	29	50	18.75	-	-	-	-	-	-	-	-	-	-	-	-	-	-	-	7.23	12.74	0.13	0.06	0.06	0.15	2.08		
LDEH20CA							32	48.1	69.1	12.3	4.15	12	M5X7	7.5	6	6	20	15.5	9.5	8.5	6	60	20	M5X16		10.31	21.13	0.22	0.16	0.16	0.24			
LDEH25SA	33	7	12.5	48	35	6.5	-	35.5	59.1	21.9	-	-	-	-	-	-	-	-	-	-	-	-	-	-	-	11.40	19.50	0.23	0.12	0.12	0.25	2.67		
LDEH25CA							35	59	82.6	16.15	4.55	12	M6X9	8	8	8	23	18	11	9	7	60	20	M6X20		16.27	32.40	0.38	0.32	0.32	0.41			

LDE series linear guide dimension table

○ LDEW-SA/LDEW-CA

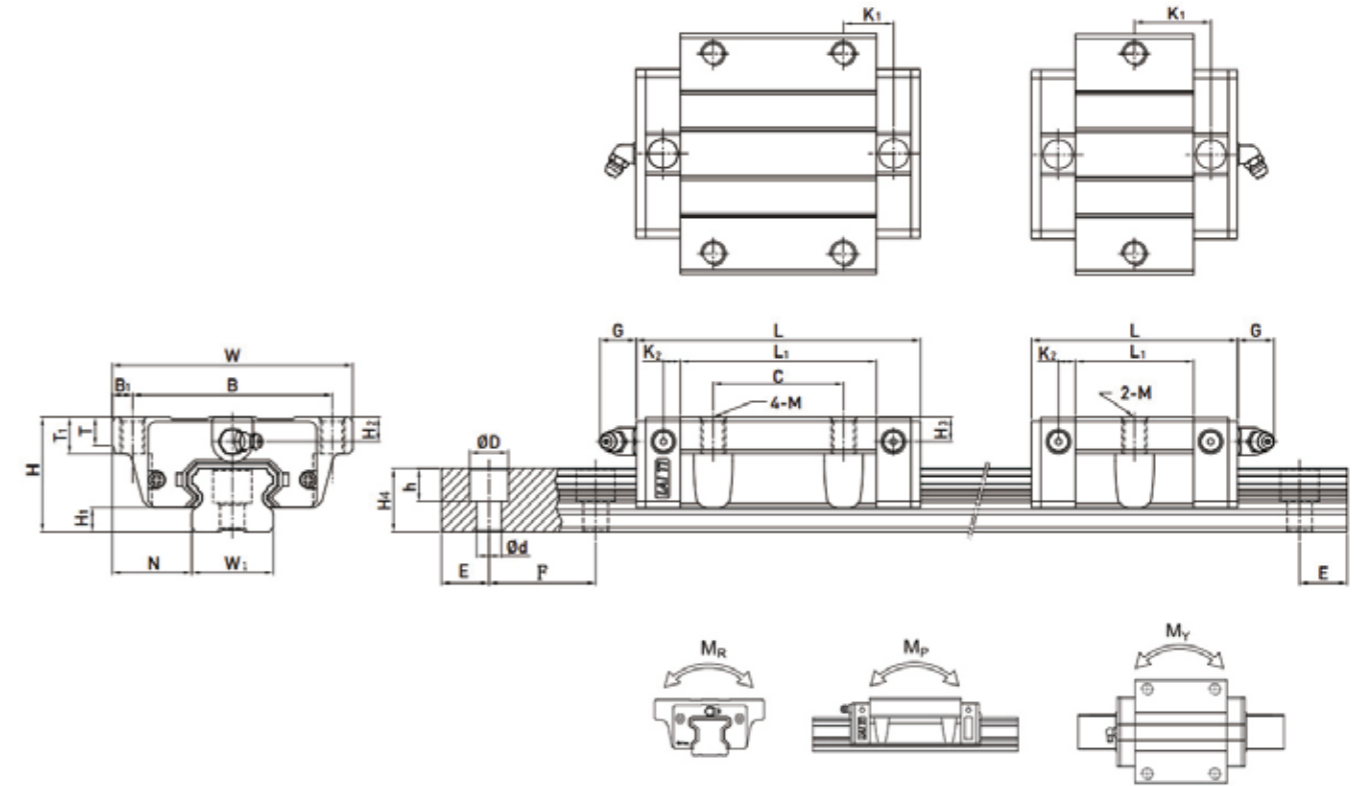

Linear Guide parameter

Note: 1kgf=9.81N

Model	Assembly dimension (mm)		Block dimension (mm)														Rail dimension (mm)										Size of fixed bolts for sliding rails (mm)	Basic dynamic load capacity C _{dyn} (kN)	Basic static load capacity C ₀ (kN)	Static permissible moment			Weight	
	H	H ₁	N	W	B	B ₁	C	L ₁	L	k ₁	k ₂	G	M	T	H ₂	H ₃	W ₁	H ₄	D	h	d	F	E	M _R	M _P	M _Y				Block	Rail			
																									KN-m	KN-m				KN-m	kg	kg/m		
LDEW15SA	24	4.5	18.5	52	41	5.5	-	23.1	40.1	14.8	-	-	-	-	-	-	-	-	-	-	-	-	-	-	-	5.35	9.40	0.08	0.04	0.04	0.12	1.25		
LDEW15CA							26	39.8	56.8	10.15	3.5	5.7	M5	7	5.5	6	15	12.5	6	4.5	3.5	60	20	M3X16		7.83	16.19	0.13	0.10	0.10	0.21			
LDEW20SA	28	6	19.5	59	49	5	-	29	50	18.75	-	-	-	-	-	-	-	-	-	-	-	-	-	-	7.23	12.74	0.13	0.06	0.06	0.19	2.08			
LDEW20CA							32	48.1	69.1	12.3	4.15	12	M6	9	6	6	20	15.5	9.5	8.5	6	60	20	M5X16		10.31	21.13	0.22	0.16	0.16	0.32			
LDEW25SA	33	7	25	73	60	6.5	-	35.5	59.1	21.9	-	-	-	-	-	-	-	-	-	-	-	-	-	-	11.40	19.50	0.23	0.12	0.12	0.35	2.67			
LDEW25CA							35	59	82.6	16.15	4.55	12	M8	10	8	8	23	18	11	9	7	60	20	M6X20		16.27	32.40	0.38	0.32	0.32	0.59			

LDE series linear guide dimension table

○ LDEW-SB/LDEW-CB

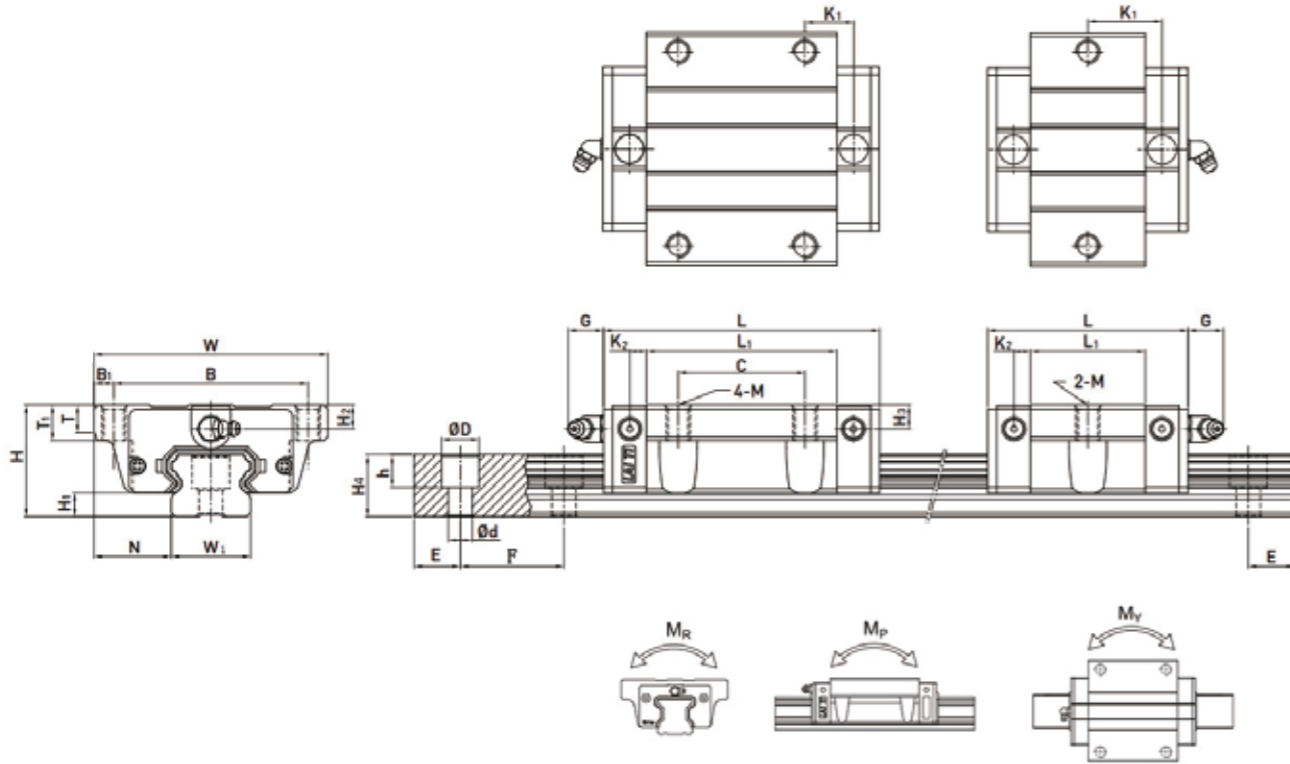

Linear Guide parameter

Note: 1kgf=9.81N

Model	Assembly dimension (mm)		Block dimension (mm)														Rail dimension (mm)										Size of fixed bolts for sliding rails (mm)	Basic dynamic load capacity $C_{dyn}(kN)$	Basic static load capacity $C_0(kN)$	Static permissible moment			Weight	
	H	H ₁	N	W	B	B ₁	C	L ₁	L	k ₁	k ₂	G	M	T	H ₂	H ₃	W ₁	H ₄	D	h	d	F	E	M _R	M _P	M _Y				Block	Rail			
																														(mm)	(kN)	(kN)	KN-m	KN-m
LDEW15SB	24	4.5	18.5	52	41	5.5	-	23.1	40.1	14.8	-	3.5	5.7	Ø4.5	7	5.5	6	15	12.5	6	4.5	3.5	60	20	M3X16	5.35	9.40	0.08	0.04	0.04	0.12	1.25		
LDEW15CB							26	39.8	56.8	10.15																7.83	16.19	0.13	0.10	0.10	0.21			
LDEW20SB	28	6	19.5	59	49	5	-	29	50	18.75	-	4.15	12	Ø5.5	9	6	6	20	15.5	9.5	8.5	6	60	20	M5X16	7.23	12.74	0.13	0.06	0.06	0.19	2.08		
LDEW20CB							32	48.1	69.1	12.3																10.31	21.13	0.22	0.16	0.16	0.32			
LDEW25SB	33	7	25	73	60	6.5	-	35.5	59.1	21.9	-	4.55	12	Ø7	10	8	8	23	18	11	9	7	60	20	M6X20	11.40	19.50	0.23	0.12	0.12	0.35	2.67		
LDEW25CB							35	59	82.6	16.15																16.27	32.40	0.38	0.32	0.32	0.59			

2-1 LDM Series Miniature Linear Guide

LDM Series construction

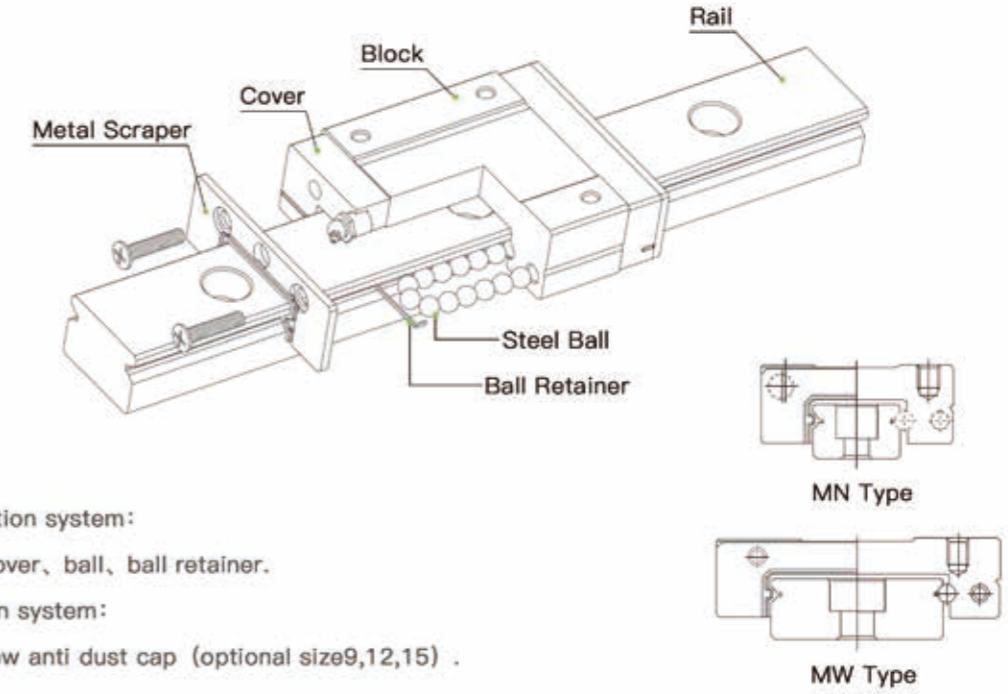

- Rolling circulation system:
Block, rail, cover, ball, ball retainer.
- Dust protection system:
End seal, screw anti dust cap (optional size 9,12,15).

Non-interchangeable linear guide product model

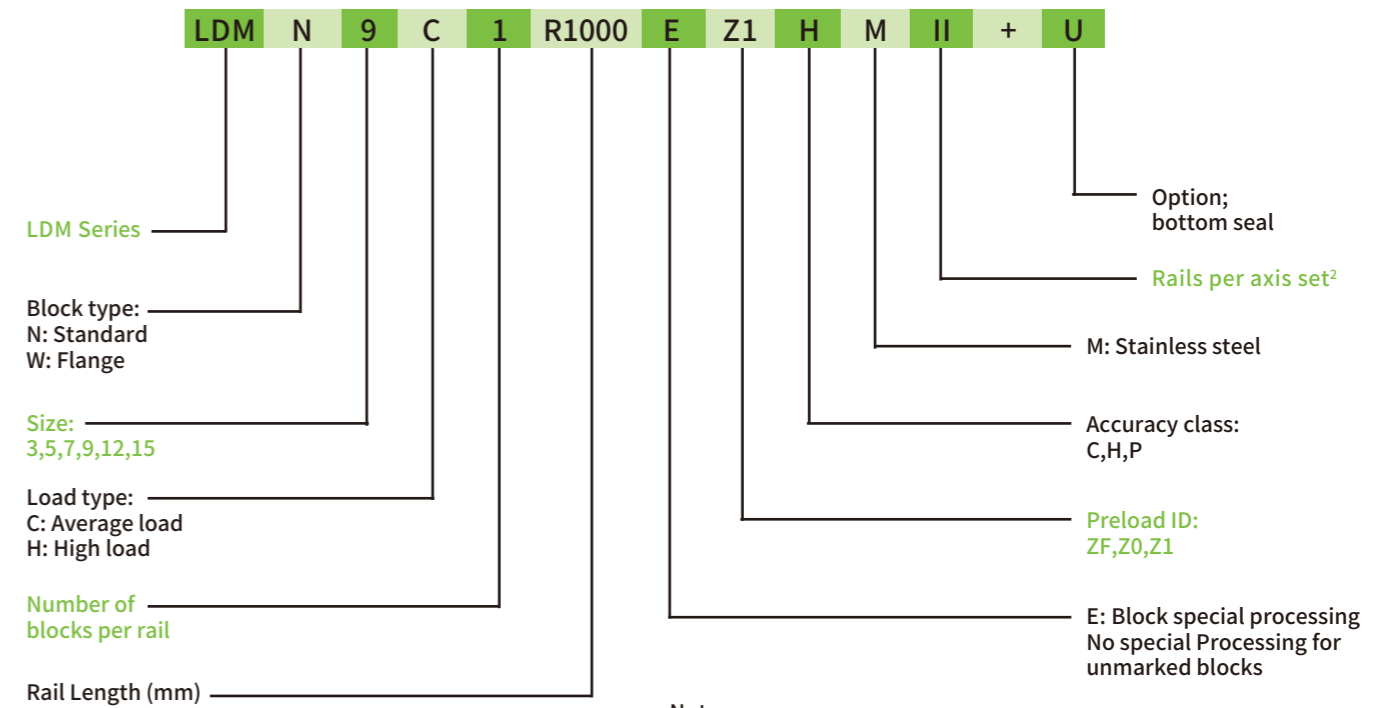

Note:
If the number of single-axis guide rails is only one guide rail, it is blank, the two marks as II, the three marks as III, and so on.

Interchangeable type block product model

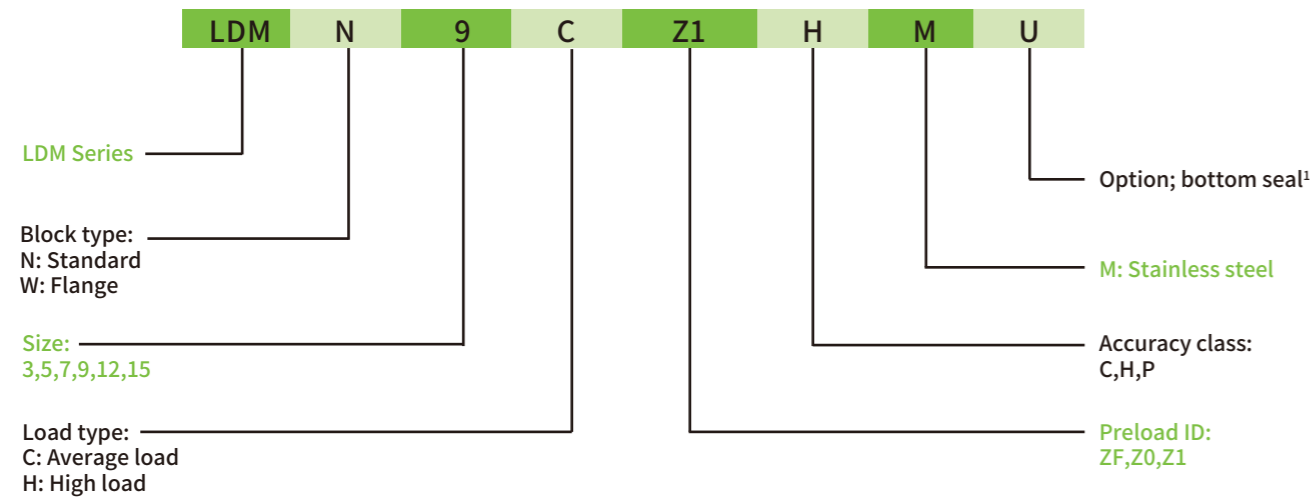

Interchangeable type rail product model

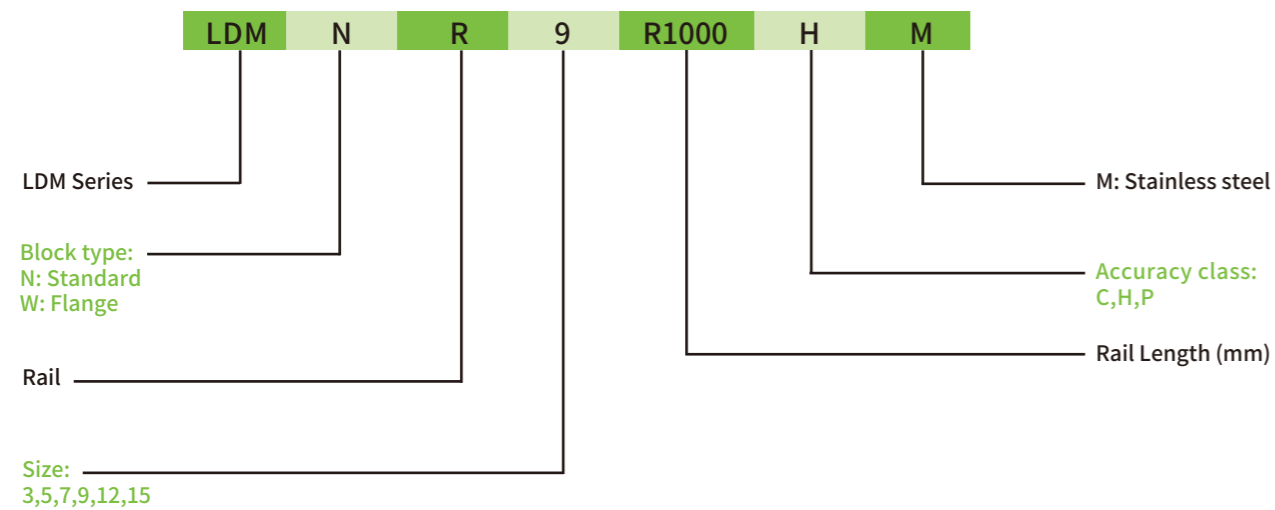

LDM series linear guide dimension table

○ LDMN-C/LDMN-H

MN3, MN5

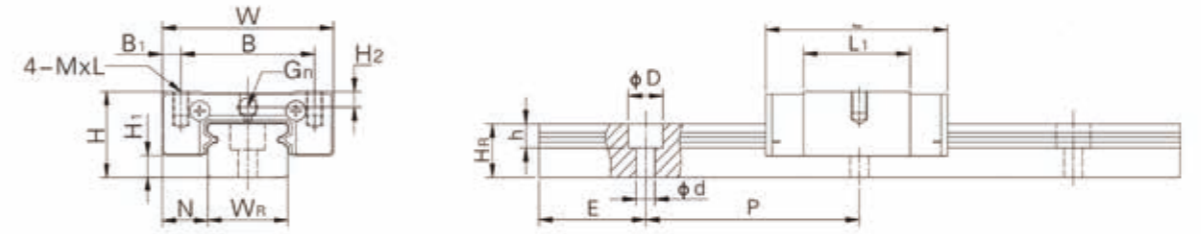

MN7, MN9, MN12, MN15

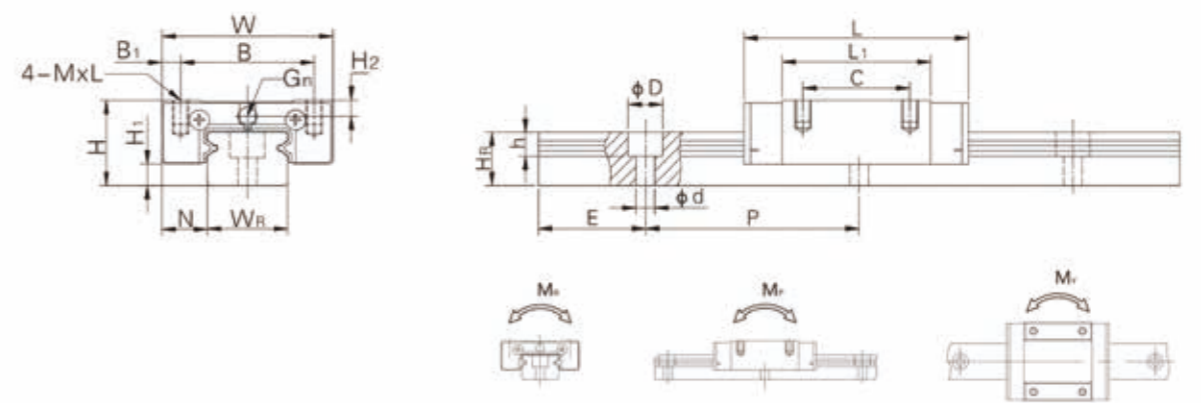

Linear Guide Parameter

Note: 1kgf=9.81N

Model	Assembly Dimension (mm)	Block Dimension(mm)											Rail Dimension(mm)					Size of fixed bolts for sliding rails (mm)	Basic dynamic load capacity C(kN)	Basic static load capacity C ₀ (kN)	Static permissible moment			Weight				
		H	H1	N	W	B	B1	C	L ₁	L	G	MxL	H ₂	W _R	H _R	D	h				d	P	E	M _R	M _p	M _y	Block	Rail
													(mm)								N-m	N-m	N-m	kg	kg/m			
LDMN 3C	4	1	2.5	8	-	-	3.5	6.7	12	-	M1.6x1.3	3	2.6	-	-	1.6	10	5	M1.6x1	0.18	0.31	0.59	0.39	0.39	-	-		
LDMN 3H							5.5	10.7	16											0.29	0.57	0.88	1.08	1.08				
LDMN 5C	6	1	3.5	12	8	2	-	9.7	16	-	M2x1.3	1	5	3.7	3.6	0.8	2.4	15	7.5	M2x6	0.54	0.84	2	1.30	1.30	0.008	0.15	
LDMN 5H							12.7	19	0.54												0.84	2	18.62	18.62	0.026			
LDMN 7C	8	1.5	5	17	12	2.5	8	13.5	22.5	-	M2x2.5	1.5	7	4.8	4.2	2.3	2.4	15	7.5	M2x6	0.98	1.24	4.7	2.84	2.84	0.010	0.22	
LDMN 7H							13	21.8	30.8												1.37	1.96	7.64	4.80	4.80	0.015		
LDMN 9C	10	2	5.5	20	15	2.5	10	18.9	28.9	-	M3x3	1.8	9	6.5	6	3.5	3.5	20	7.5	M3x8	1.86	2.55	11.76	7.35	7.35	0.016	0.38	
LDMN 9H							16	29.9	39.9												2.55	4.02	19.6	18.62	18.62	0.026		
LDMN12C	13	3	7.5	27	20	3.5	15	21.7	34.7	-	M3x3.5	2.5	12	8	6	4.5	3.5	25	10	M3x8	2.84	3.92	25.48	13.72	13.72	0.034	0.65	
LDMN12H							20	32.4	45.4												3.72	5.88	38.22	36.26	36.26	0.054		
LDMN15C	16	4	8.5	32	25	3.5	20	26.7	42.1	4.5	M3x4	3	15	10	6	4.5	3.5	40	15	M3x10	4.61	5.59	45.08	21.56	21.56	0.059	1.06	
LDMN15H							25	43.4	58.8												6.37	9.11	73.5	57.82	57.82	0.092		

LDM series linear guide dimension table

LDMW-C/LDMW-H

MW3, MW5

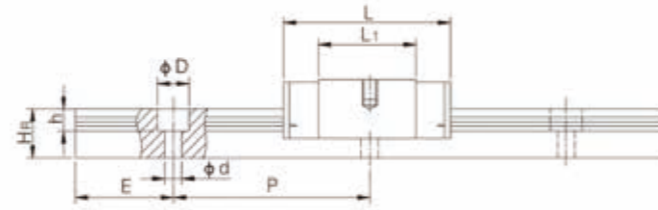
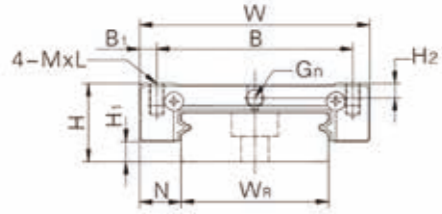

MW7, MW9, MW12

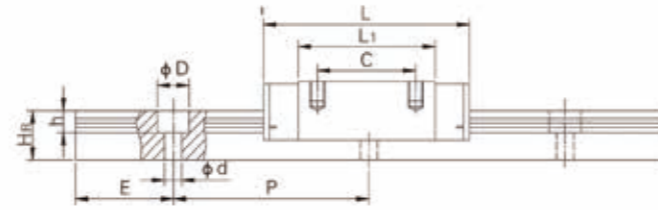
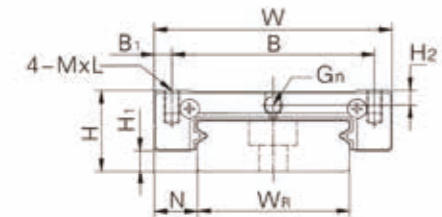

MW15

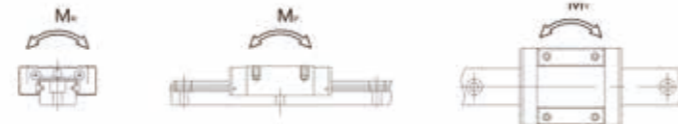
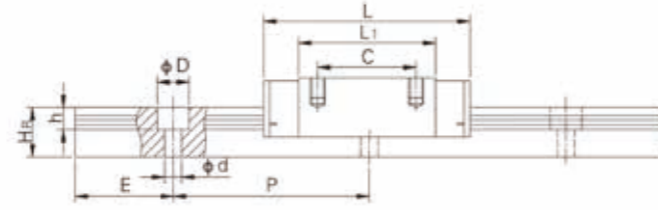
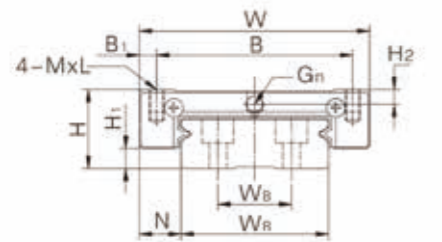

Linear Guide Parameter

Note: 1kgf=9.81N

Model	Assembly Dimension (mm)		Block Dimension(mm)										Rail Dimension(mm)										Size of fixed bolts for sliding rails (mm)	Basic dynamic load capacity C(kN)	Basic static load capacity C ₀ (kN)	Static permissible moment			Weight	
	H	H1	N	W	B	B1	C	L ₁	L	G	MxL	H ₂	W _R	W _B	H _R	D	h	d	P	E	M _R	M _P				M _V	Block	Rail		
	mm	mm	mm	mm	mm	mm	mm	mm	mm	mm	mm	mm	mm	mm	mm	mm	mm	mm	mm	mm	N·m	N·m				N·m	kg	kg/m		
LDMW 5C	6.5	1.5	3.5	17	13	2	-	13.6	20.6	-	M2x2.5	1	10	-	4	4.8	1.6	2.9	20	7.5	M2.5x6	0.68	1.18	5.5	2.7	2.7	0.016	0.37		
LDMW 5H								17.6	24.6																					
LDMW 7C	9	2	5.5	25	19	3	10	21	31.2	-	M3x3	1.85	14	-	5.2	6	3.2	3.5	30	10	M3x6	1.37	2.06	15.7	7.14	7.14	0.020	0.51		
LDMW 7H							19	30.8	41													1.77	3.14	23.45	15.53	15.53	0.029			
LDMW 9C	12	3	6	30	21	4.5	12	27.5	39.3	-	M3x3	2.4	18	-	7	6	4.5	3.5	30	10	M3x8	2.75	4.12	40.12	18.96	18.96	0.040	0.91		
LDMW 9H					23	3.5	24	38.5	50.7													3.43	5.89	54.54	34.00	34.00	0.057			
LDMW12C	14	3	8	40	28	6	15	31.3	46.1	-	M3x3.6	2.8	24	-	8.5	8	4.5	4.5	40	15	M4x8	3.92	5.59	70.34	27.80	27.80	0.071	1.49		
LDMW12H							28	45.6	60.4													5.1	8.24	102.7	57.37	57.37	0.103			
LDMW15C	16	4	9	60	45	7.5	20	38	54.8	-	M4x4.2	3.2	42	23	9.5	8	4.5	4.5	40	15	M4x10	6.77	9.22	199.34	56.66	56.66	0.143	2.86		
LDMW15H							35	57	73.8	5.2												8.93	13.38	299.01	122.60	122.60	0.215			

3-1 Features of LTROBOT Ball Screw

(1) High Reliability

LTROBOT applies stringent quality control standards on every production process. With proper lubrication and use, trouble-free operation for an extended period of time is possible.

(2) Smooth Operation

The high efficiency of ball screw is vastly superior than conventional screws as shown in Fig 3.1.1. It takes less than 30% torque to make the linear motion into rotary motion.

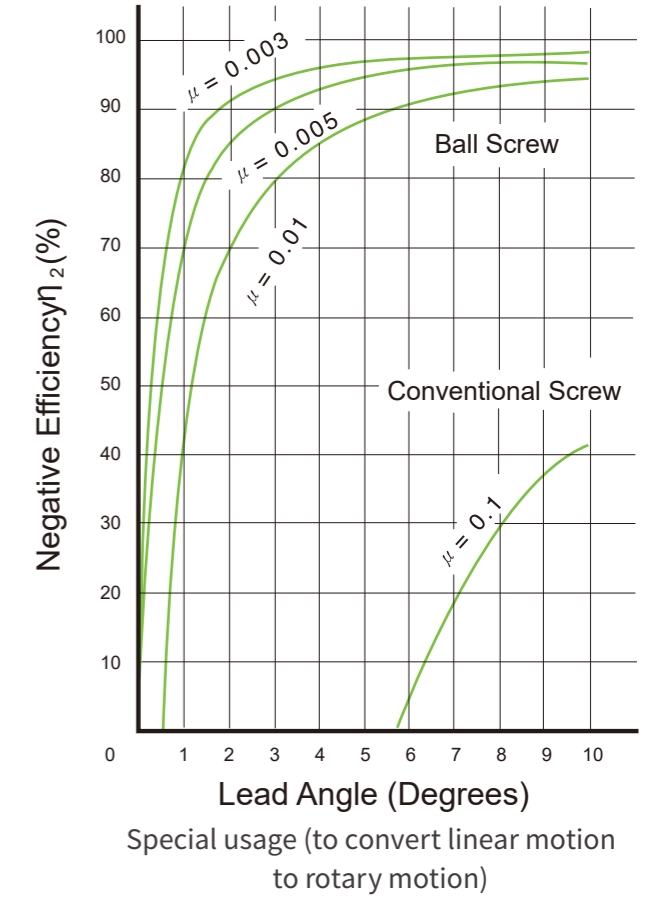
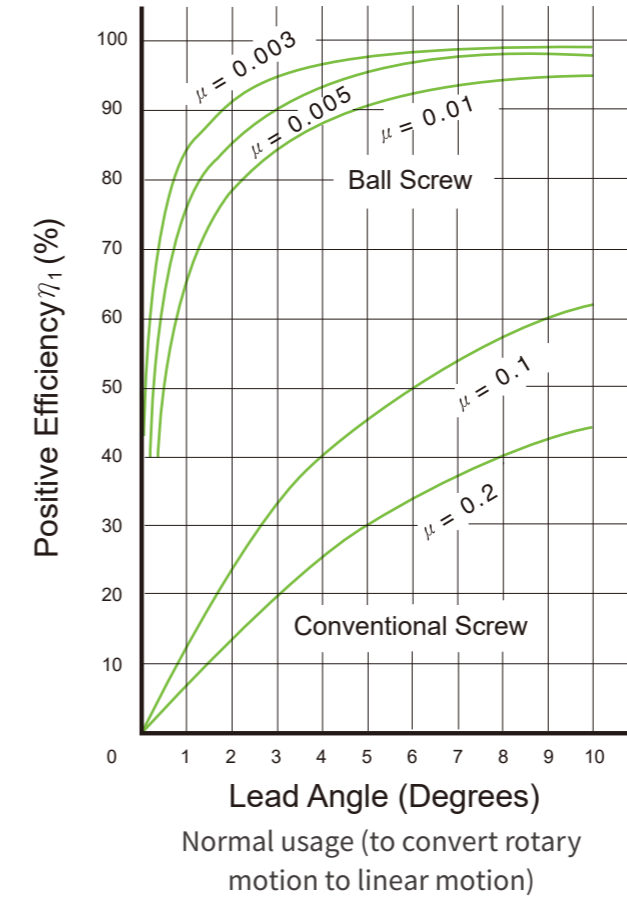

μ : friction coefficient

$$P = \frac{2\pi\eta_1 \times T}{\ell}$$

T = Torque kgf · cm
P = Force kgf
= Lead cm
η₁ = Efficiency

$$T = \frac{\ell \times \eta_2 \times P}{2\pi}$$

T = Torque kgf · cm
P = Force kgf
= Lead cm
η₂ = Efficiency

Fig 3.1.1 Mechanical Efficiency of Ball Screws

(3) High Rigidity and Preload

As figure 3.1.2 shown in below, the ball screw of LTROBOT is designed with Gothic arch groove, which makes the screw easy to rotate even using minimum axial play. To make the rigidity more appropriate to using condition, you can change the preload between one or two screw nuts to reduce axial play.



Fig 3.1.2 Groove Shape of LTROBOT Precision Ball Screw

(4) Circulation Method

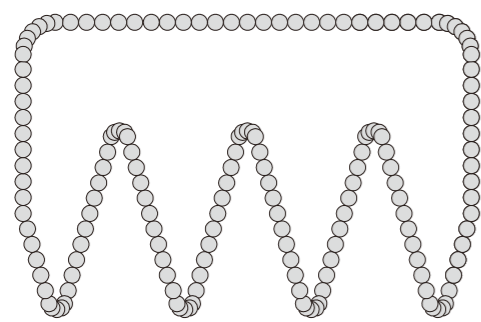

Fig 3.1.3 External Ball Circulation Nuts

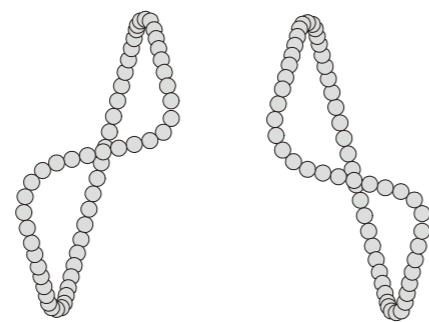

Fig 3.1.4 Internal Ball Circulation Nuts

(5) High Durability

As figure 3.1.2 shown in below, the ball screw of LTROBOT is designed with Gothic arch groove, which makes the screw easy to rotate even using minimum axial play. To make the rigidity more appropriate to using condition, you can change the preload between one or two screw nuts to reduce axial play.

Item	Material	Hardness
Screw	SCM450 S55C	HRC 58°~62°
Nut	SCM415H	HRC 58°~62°
Steel Ball	SUJ2	HRC 62°UP

Table 3.1.1 Material and Heat Treatment

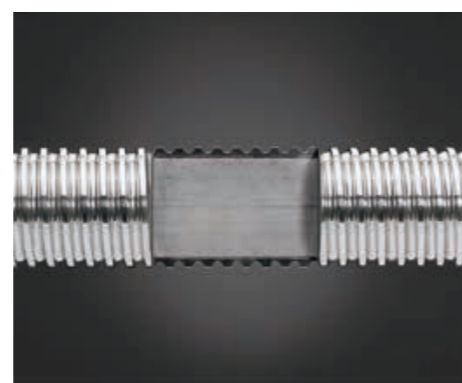
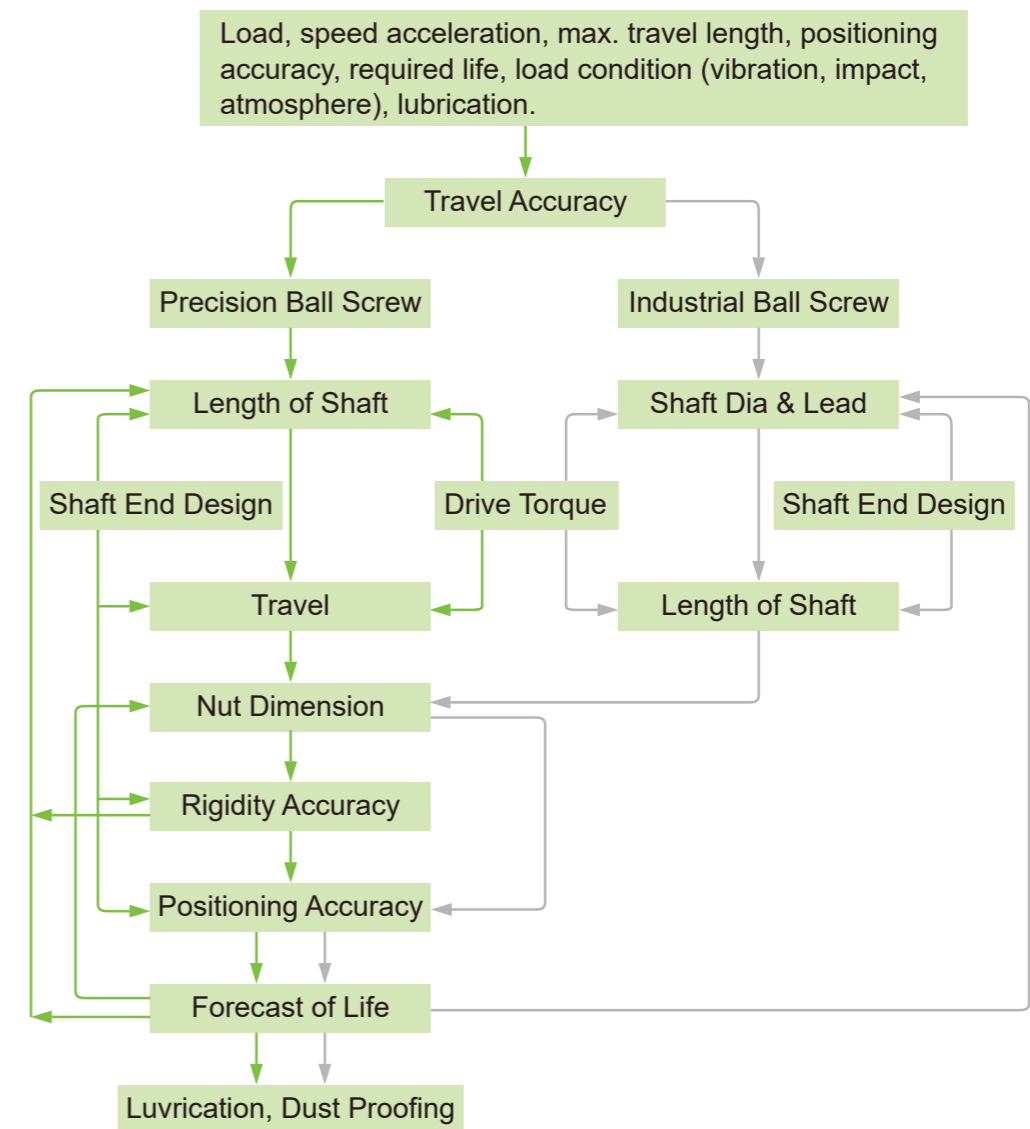

Fig 3.1.5 Heat Treatment

3-2 Ball Screw Selection Procedure



3-3 Accuracy

3-3-1 Lead/Travel Accuracy

According to the standard of JIS, we classified our lead accuracy through E, e, e 300 and e 2π, four main regulations. As figure 3.3.1 ~ 3.3.3 shown in below, all the definition and tolerance are specified. To test the accumulated travel deviations for grade C7 and C10, the tolerance will be chosen in random 300mm of useful length and evaluated if it is qualified with the e300 table of 3.3.3.

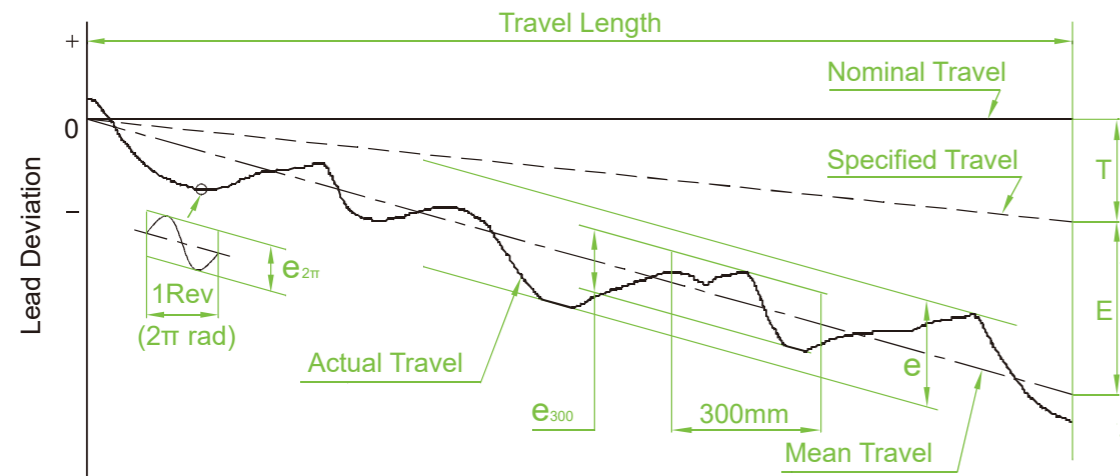

Fig 3.3.1 Diagram of Lead Accuracy

Terms	Reference	Definition	Allowable
Travel Compensation	T	Travel compensation is the deduction between specified and nominal travel in the useful travel. A slightly smaller value compared with nominal travel is often selected by customer, to compensate for an expected elongation caused by temperature rise or external load. Therefore " T " is usually a negative value. Note : if no compensation is needed, specified travel is the same as nominal travel.	
Actual Travel		Actual travel is the axial displacement of the nut relative to the screw shaft.	
Mean Travel		Mean travel is the linear best fit line of actual. This could be obtained by the least squares method. This line represents the tendency of actual travel.	
Mean Travel Deviation	E	Mean travel deviation is the deduction between mean travel and specified travel within travel length.	Table 3.3.2
Travel Variations	e	Travel variations is the coverage of 2 lines drawn parallel to the mean travel.	Table 3.3.2
	e ₃₀₀	Maximum width of variation within the travel length.	Table 3.3.3
	e _{2π}	Actual width of variation for the length of 300mm taken anywhere within the travel length. Wobble error, actual width of variation for one revolution (2π radian)	Table 3.3.3

Table 3.3.2 Mean Travel Deviation (±E) and Travel Variation (e) (JIS B 1192)

Unit : μm

Travel Length (mm)	Grade	Incl.	C0		C1		C2		C3		C5		C7	C10
			±E	e	±E	e	±E	e	±E	e	±E	e	e	e
Over	100	3	3	3	3.5	5	5	7	8	8	18	18	±50/300mm	±210/300mm
100	200	3.5	3	4.5	5	7	7	10	8	20	18			
200	315	4	3.5	6	5	8	7	12	8	23	18			
315	400	5	3.5	7	5	9	7	13	10	25	20			
400	500	6	4	8	5	10	7	15	10	27	20			
500	630	6	4	9	6	11	8	16	12	30	23			
630	800	7	5	10	7	13	9	18	13	35	25			
800	1000	8	6	11	8	15	10	21	15	40	27			
1000	1250	9	6	13	9	18	11	24	16	46	30			
1250	1600	11	7	15	10	21	13	29	18	54	35			
1600	2000			18	11	25	15	35	21	65	40			
2000	2500			22	13	30	18	41	24	77	46			
2500	3150			26	15	36	21	50	29	93	54			
3150	4000			30	18	44	25	60	35	115	65			
4000	5000					52	30	72	41	140	77			
5000	6300					65	36	90	50	170	93			
6300	8000							110	60	210	115			
8000	10000									260	140			
10000	12500									320	170			

Table 3.3.3 Variation per 300mm (e₃₀₀) and Wobble Error (e_{2π}) (JIS B 1192)

Unit : μm

Grade	C0	C1	C2	C3	C5	C7	C10
e ₃₀₀	3.5	5	7	8	18	50	210
e _{2π}	2.5	4	5	6	8		

3-3-2 Axial Play

Axial play of LTROBOT precision ball screw is shown in

Table 3.3.4 Classification of Axial Play

Grade	P0	P1	P2	P3	P4
Axial Play	Yes	No	No	No	No
Preload	No	No	Light	Medium	Heavy

Excessive preload increases the friction torque and generates heat which will reduce the life expectancy. However, insufficient preload will reduce stiffness and increase the possibility of lost motion. LTROBOT recommends that the preload applied on CNC machine tools should not heavier than 8% of the dynamic load; 5% for industrial automation X-Y table.

Table 3.3.5 The reference spring force of (P2)

Model No.	Spring Force (Kg) Single Nut	Spring Force(Kg) Double Nut
1605	0.1~0.3	0.3~0.6
2005	0.1~0.3	0.3~0.6
2505	0.2~0.5	0.3~0.6
3205	0.2~0.5	0.5~0.8
4005	0.2~0.5	0.5~0.8
2510	0.2~0.5	0.5~0.8
3210	0.3~0.6	0.5~0.8
4010	0.3~0.6	0.5~0.8
5010	0.3~0.6	0.8~1.2
6310	0.6~1.0	0.8~1.2
8010	0.6~1.0	0.8~1.2

Table 3.3.6 Axial Play (P0) Clearance in the Axial Direction of Rolled and Ground Ball Screw Unit : mm

Nominal Diameter	Rolled Ball Screw Clearance in the Axial Direction (max.)	Ground Ball Screw Clearance in the Axial Direction (max.)
Ø04~Ø14 miniature ball screw	0.05	0.015
Ø15~Ø40 middle size of ball screw	0.08	0.025
Ø50~Ø100 big size of ball screw	0.12	0.05

3-3-3 Definition of Mounting Accuracy and Tolerance on Ball Screw

The main items of the mounting accuracy of ball screw are listed in below.

- (1) Periphery run-out of the supporting part of the screw shaft to the screw groove.
- (2) Concentricity of a mounting portion of the shaft to the adjacent ground portion of the screw shaft.
- (3) Perpendicularity of the shoulders to the adjacent ground portion of the screw shaft.
- (4) Perpendicularity of the nut flange to the axis of the screw shaft.
- (5) Concentricity of the ball nut diameter to the screw groove.
- (6) Parallelism of the mounting surface of a ball nut to the screw groove.
- (7) Total run-out of the screw shaft to the axis of the screw shaft.

All LTROBOT ball screws are manufactured, inspected and guaranteed to be within specifications.

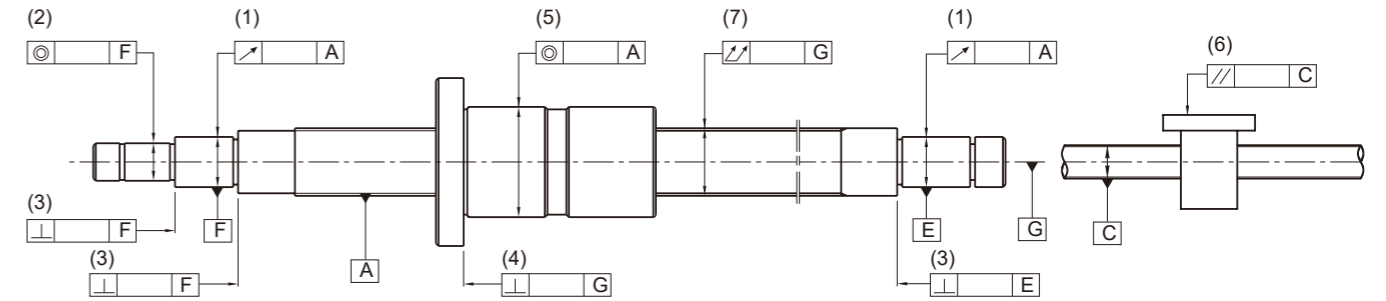

Fig 3.3.2 Mounting Accuracy and Tolerance

3-3-4 Preload Torque

As figure 3.3.3 shown in below, it specified all the type of preload torque generated by rotating a preloaded ball screw.

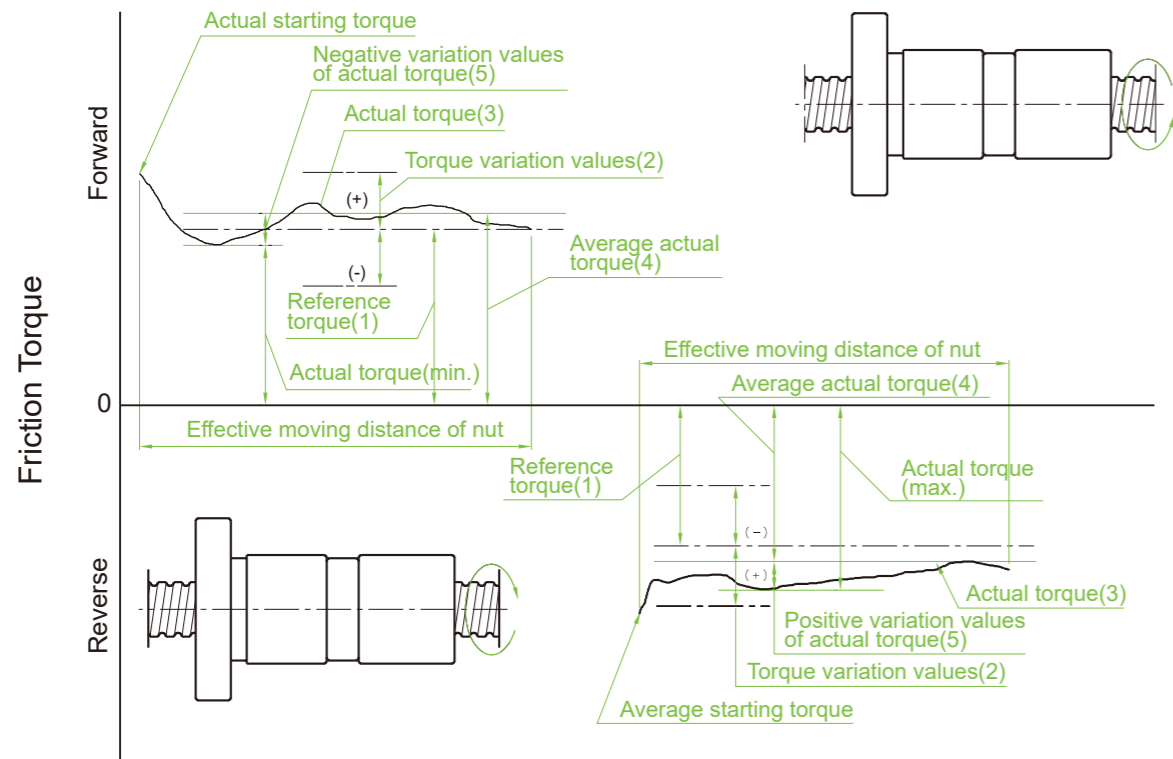

Fig 3.3.3 Descriptions of preload torque

Glossary

(1) Preload

To generate the inner force inside the ball screw to decrease the clearance and increase the rigidity, a set of one gage (approximately 2μ) larger steel balls is filled inside the nut or two nuts which are executing mutual displacement in axial direction.

(2) Preload dynamic torque

The dynamic torque required for continuously rotating the screws shaft or the nuts under unload condition and the preload has applied to the ball screws.

(3) Reference torque

The targeted preload dynamic torque Fig 3.3.3-(1)

(4) Torque variation values

The variation values of the targeted preload torque variation rates are specified generally based on JIS standards as indicated in Fig 3.3.3.

(5) Torque variation rate

The variation ratio of reference torque.

(6) Actual torque

The actual measured preload dynamic torque of the ball screws.

(7) Average actual torque

The arithmetic average of the maximal and minimal actual torque values measured when the nuts are doing reciprocating movements.

(8) Actual torque variation values

After the nut doing reciprocating movements on the effective length of the thread, the biggest variation tested will be the actual torque variation value, which is covered between the positive and negative minimum value relative to the actual torque.

(9) Actual torque variation rate

The rate of actual torque variation values in relation of the average actual torque.

Table 3.3.7 Permissible ranges of torque variation rates

Reference torque kgf·cm		Effective threading length mm										
		Below 4000					4000~10000					
		Slenderness 1 : below 40					Slenderness1 : 40~1 : 60					
Over	Incl	Grade			Grade			Grade				
		C0	C1	C2, C3	C5	C0	C1	C2, C3	C5	C1	C2, C3	C5
2	4	±35%	±40%	±45%	±55%	±45%	±45%	±55%	±65%	-	-	-
4	6	±25%	±30%	±35%	±45%	±38%	±38%	±45%	±50%	-	-	-
6	10	±20%	±25%	±30%	±35%	±30%	±30%	±35%	±40%	-	±40%	±45%
10	25	±15%	±20%	±25%	±30%	±25%	±25%	±30%	±35%	-	±35%	±40%
25	63	±10%	±15%	±20%	±25%	±20%	±20%	±20%	±30%	-	±30%	±35%
63	100	-	-	±15%	±20%	-	-	±20%	±25%	-	±25%	±30%

Remarks : 1. Slenderness is the value of dividing the screws shaft outside diameter with the screws shaft threading length.
2. For reference torque less than 2 kgf · cm, LTROBOT specifications will apply.

Calculation of Reference Torque T_P

The equation for computing reference torque of the ball screws is given in following :

$$T_P = 0.05 (\tan\beta)^{-0.5} \cdot \frac{F_{ao} \cdot \ell}{2\pi}$$

Where, F_{ao} = Preload (kgf)
β = Lead angle
ℓ = Lead (cm)

Measurement Conditions

The measure condition as indicated in Fig 3.3.4, the preload dynamic torque will be the multiplication of F (The force to make the nut stay still during rotating the screw) and L (The arm of force).

$$T_P = F \cdot L$$

Measure conditions

(1) Measurement is executed under the condition of unattached with scraper.

(2) The rotating speed during measurement maintains at 100 rpm.

(3) According to JSK2001(industrial lubrication oil viscosity standard), the lubrication oil used should be in compliance with ISO VG68.

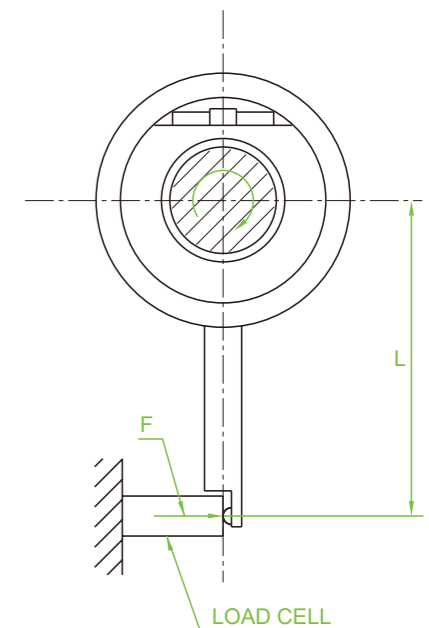

Fig 3.3.4 Preload dynamic torque measuring method

3-4 Positioning Accuracy

Among the factors that cause feed accuracy errors, lead accuracy and feed system rigidity are the key points for review, while other factors such as heat deformation due to temperature rise as well as assembly accuracy for the guiding surface, etc. should also be considered.

3-4-1 Accuracy Selection

Table 3.4.1 shows the recommended application ranges for various ball screws accuracy classes based on different.

Table 3.4.1 Examples of ball screws accuracy classes for different uses

Application			Accuracy Grade						
			C0	C1	C2	C3	C5	C7	C10
NC Machine Tools	Lathe	X	○	○	○	○	○	○	
		Y							
	Milling Machine Boring Machine	XY		○	○	○	○	○	
		Z			○	○	○	○	
	Machine Center	XY		○	○	○	○	○	
		Z			○	○	○	○	
	Jig Borer	Y	○	○					
		Z	○	○					
	Drilling Machine	XY				○	○	○	
		Z					○	○	
	Grinding Machine	X	○	○	○	○	○	○	
		Z		○	○	○	○	○	
	Electro-discharge Machine (EDM)	XY		○	○	○	○	○	
		(Z)			○	○	○	○	
	Wire Cut (EDM)	Y		○	○	○			
UV			○	○	○	○	○		
Punching Press	XY				○	○	○		
Laser Cutting Machine	XY				○	○			
	Z				○	○			
Wood Working Machine				○	○	○	○	○	
Machines of General use and special Use					○	○	○	○	○
Semiconductor Machines	Explosure Equipments		○	○					
	Chemical Treatment				○	○	○	○	
	Wire Bonder			○	○	○			
	Prober	○	○	○	○				
	Inserter			○	○	○	○		
	PCB Driller			○	○	○	○		
Industrial Robots	Orthogonal Type	As'sy		○	○	○	○	○	
		Others					○	○	○
	Multi-joints Type	As'sy			○	○	○		
		Others				○	○	○	
SCARA Type			○	○	○	○			
Machines for Steel molding							○	○	○
Injection Molding Machines							○	○	○
Three-Dimensional Measuring Machines			○	○	○				
Business Machines							○	○	○
Pattern Image Machines			○	○					
Nuclear	Rod Control				○	○	○		
	Mechnaical Snubber						○	○	
Aircrafts						○	○		

3-4-2 Countermeasure Against Thermal Displacement

Thermal displacement of the screw shaft results in deterioration of the position accuracy. The magnitude of the thermal displacement is calculated as follows :

$$\Delta l = \alpha \cdot \Delta t \cdot L$$

Δl : Thermal displacement

α : Coefficient of thermal expansion

Δt : Temperature rise (deg) at screw shaft

L : Effective length of screw thread

Namely, the screw shaft develops elongation of 12μm per 1m when the temperature rises by 1°C. The ball screw, which lead has been machined to high accuracy, may fail to meet high level requirements because of the thermal displacement due to temperature rise. As high speed is applied during ball screw usage, the heat will rise as well and cause more influence.

The thermal displacement countermeasures for ball screws include the following :

(1) Control of heat generation

- Optimization of preload
- Correct selection and supply of lubricant
- Increase in ball screw lead, with reduced rotation speed

(2) Forced cooling

- Hollow screw shaft to allow cooling fluid to flow through
- Cooling of screw shaft exterior with cooling oil or air

(3) Avoid influence of temperature rise

Warming up the machine through high speed to attain the stable temperature :

- Operates after the temperature become stable
- Pre-tension on screw shaft
- Preset a negative value on target value of the cumulative lead.
- Use the closed loop for positioning

3-5 Service Life Design

3-5-1 Service Life of Ball Screws

Even the ball screw is used under correct conditions, it would still fail after a period time of usage. From the beginning to the unusable condition of ball screw, this period of time is called service life of ball screw, which is generally classified into the fatigue life when delamination phenomenon occurs and the accuracy deterioration life caused by wear-out, etc.

3-5-2 Basic Static Load Rating C_{0a}

The basic load rating is an axial static load which will produce a permanent deformation at contact points of the steel balls to ball grooves equal to 0.01% of ball diameter.

3-5-3 Basic Dynamic Load Rating C_a

The basic dynamic load rating is an axial load which allow 90% of a group of identical ball screws (rotated under the same condition) to rotate without flaking for 10⁶ revolutions. This basic dynamic load rating is shown in the table of dimensions.

Relation between load and service life $L_a = \left(\frac{1}{P}\right)^3$ L : Service life P : Load

3-5-4 Fatigue Life

Average load P_e

(1) When axial load keeps changing, please calculate in order the average load for the equivalent fatigue life under different load condition changes. (see Table 3.5.1)

$$(P_e = \frac{P_1^3 n_1 t_1 + P_2^3 n_2 t_2 + \dots + P_n^3 n_n t_n}{n_1 t_1 + n_2 t_2 + \dots + n_n t_n})^{\frac{1}{3}} \text{ (kgf)}$$

Axial Load (kgf)	Rotating Speed (min ⁻¹)	Time(%)
P1	n1	t1
P2	n2	t2
⋮	⋮	⋮
Pn	nn	tn

But, $t_1 + t_2 + t_3 + \dots + t_n = 100$

Table 3.5.1 Service Life in Different Application.

Usage	Life in hours (h)
Working machines	20000
General industrial machines	10000
Automatic control machines	15000
Measurement machines	15000

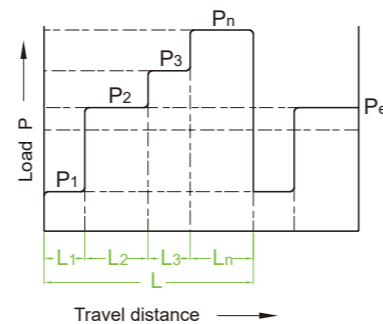

Fig 3.5.1

$$P_e = \frac{2P_{max} + P_{min}}{3} \text{ (kgf)}$$

P_{max} : Maximal axial load (kgf)

P_{min} : Minimal axial load (kgf)

(2) When load changes according to sine curve (see Fig 3.5.2)

$P_e \cong 0.65 P_{max}$ (Fig A)

$P_e \cong 0.75 P_{max}$ (Fig B)

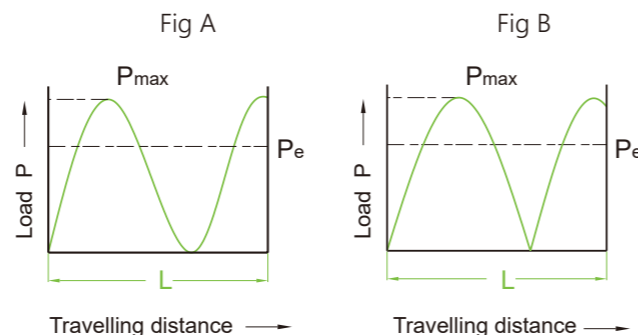

Fig 3.5.2

3-5-5 Calculation of Service Life

The fatigue life is generally expressed by the total number of revolutions. The total rotation hours or total travel distance may also be used to express service life. The fatigue life is calculated as follow :

$$L = \frac{C_a}{P_a \cdot f_w}^3 \cdot 10^6$$

$$L_t = \frac{L}{60n}$$

$$L_s = \frac{L \cdot \ell}{10^6}$$

Where

L : Rated fatigue life (rev)

L_s : Life in travel distance (km)

P_a : Axial load (kgf)

f_w : Load Coefficient

(Required coefficient to operate)

L_t : Life in hours (h)

C_a : Basic dynamic load rating (kgf)

n : Rotating speed (rpm)

ℓ : Lead (mm)

Table 3.5.2 Load Factor (f_w)

Vibration and impact	Velocity (V)	f_w
Minor	$V \leq 0.25$ m/s Very Low	1~1.2
Little	$0.25 < V \leq 1$ m/s Low	1.2~1.5
Moderate	$1 < V \leq 2$ m/s Medium	1.5~2
Heavy	$V > 2$ m/s High	2~3.5

Table 3.5.3 Factor of Safety (f_s)

Usage	Operation	f_s
Machine tool	Normal operation	1.0 ~ 1.3
	Operation with impact and vibration	2.0 ~ 3.0
Industrial machine	Normal operation	1.0 ~ 1.5
	Operation with impact and vibration	2.5 ~ 7.0

Basic Dynamic Load Rating C_a

$$C_a = P_e \cdot f_s$$

Basic Static Load Rating C_{0a}

$$C_{0a} = P_{max} \cdot f_s$$

3-6 Cautions About Use of Ball Screws

Ball screw assemblies are delicate components. There ore,extra care must be taken to prevent the ball track from damages that caused by edged component or tools. Meanwhile, to prevent steel ball fall out of the nut through the disassembly of screw and nut or over stroke, please be careful while operating. If the steel ball falls out, please contact with LTROBOT for further instruction. Do not attempt to reassemble, which might cause permanent damage to the ball screw.)

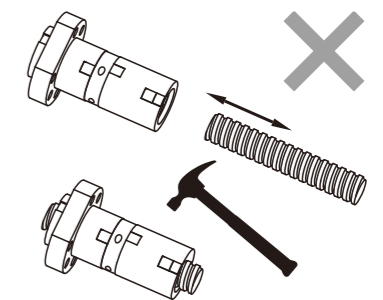

Fig 3.6.1 Error installation

If disassemble is required, please use a transfer pipe which has minor diameter than the screw diameter to transfer the nut to prevent falling out of the steel balls.

3-6-1 Lubrication

Adequate lubrication must be provided when ball screw is used, insufficient lubrication will result in collision of metal, which leads to increase of friction and detrition, thus cause failure or shortening the service life.

Lubricants applied to ball screws can be divided into 2 types, namely lubricating oil and consistent grease. In general speaking, in respect of maintenance, consistent grease will lead to increase of dynamic friction torque linearly along with increase of rotating speed, hence oil lubrication is deemed the better way when speed exceeds 3-5 m/min; however, don't forget the fact that there have been examples that using grease has been capable of achieving speed of 10 m/min, with respect to the equipment.

In terms of equipments, there are some cheaper lubricant that can be used. In general, to fully utilize the function of ball screw, lubricating oil of 5m/minute is the best option to choose. In figure 3.6.1, we provide the standard of lubricating oil inspection and supplement interval. Before replenishing, please clean up the previous grease to continue.

Table 3.6.1 Inspection of lubrication and interval of refill

Method	Interval	Check Item	Replenish or Change Interval
Auto. Periodial oil supply	Weekly	Oil level, contamination	Add at each check, as required depending on tank level
Grease	Initially 2~3 months	Contamination on entry of chip	replenish yearly or according to the inspection result.
Oil bath	Daily	Oil level	To be determined according to consumption

3-6-2 Dust Proof / Prevention

Any foreign matter or water, if entering to the ball screw, may increase friction and cause damage. For example, the entry of chips or cutting oil may be expected with machine tools according to the work environment. Where entry of foreign matter is anticipated, use a bellows or telescopic cover as shown in Fig 3.6.2, to cover the screw shaft completely.

3-6-3 Offset Load

When offset load phenomenon occurs, screw life and noise tend to be directly affected, which would usually be accompanied with hand feel of rough running. As the smoothness of singleshaft and assembled ball screw might be different. In addition to single shaft's accuracy, the offset phenomenon was mostly occurred by failed assemble accuracy which is shown in Fig 3.6.3.

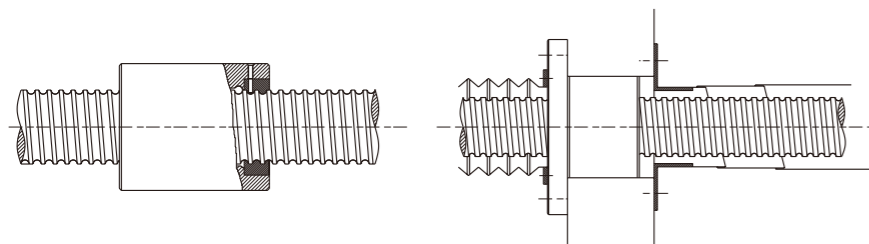

Fig 3.6.2 Dust proof Method by Telescopic Cover and Bellows

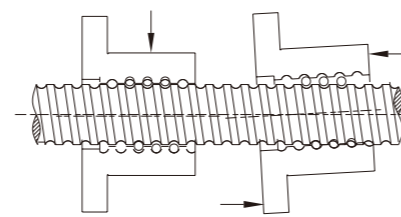
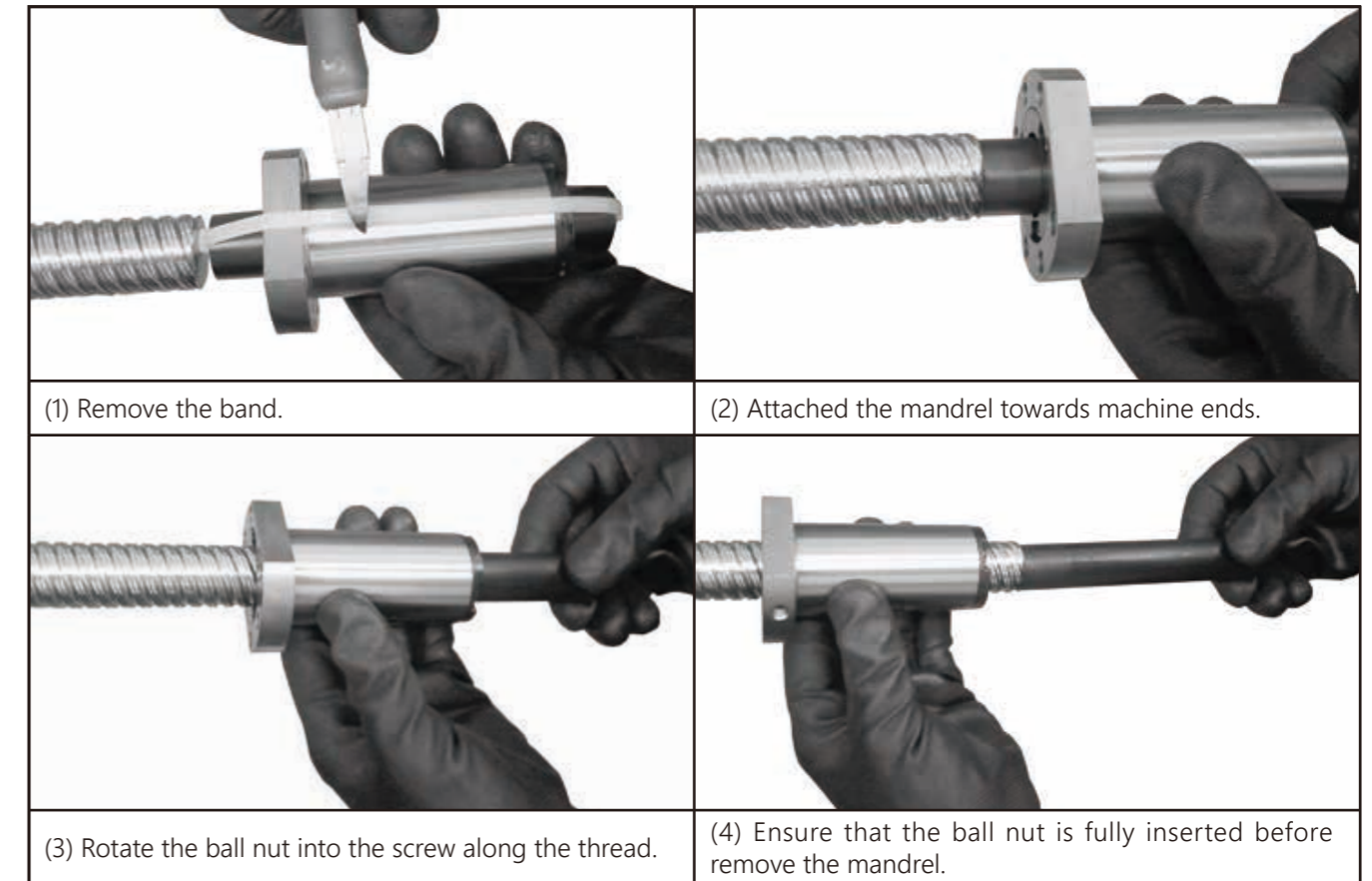

Fig 3.6.3 Offset Load

3-6-4 Assembling the Ball Screws

If rolled ball nut is shipped un-assembled please follow the procedure as below.

Table 3.6.2 Procedure



(1) Remove the band.

(2) Attached the mandrel towards machine ends.

(3) Rotate the ball nut into the screw along the thread.

(4) Ensure that the ball nut is fully inserted before remove the mandrel.

3-6-5 Machining Specifications

(1) For the Ball Screws with internal or end cap type circulation ball nut, it is required to have at least one end with complete thread to the end of screw, it is also required to have the journal area is with diameter to be smaller than the diameter of thread root as Fig 1.10.4 shown.

(2) The thread on screw shaft are hardened by induction hardening. It shall cause about 10~20mm at both ends journal purpose. The unhardened area will be labeled.

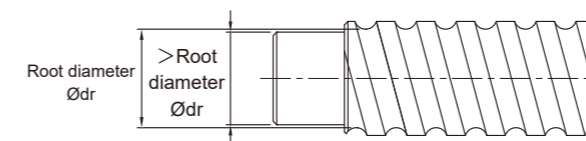

Fig 3.6.4 For Internal Circulation

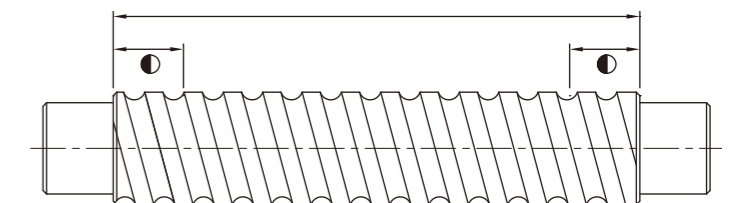

Fig 3.6.5 Harden Area

3-7 Nominal Model Code of Ball Screw

SFU R 025 05 T4 D G C5 - 600 - P1 - B2 + N3 N3

① ② ③ ④ ⑤ ⑥ ⑦ ⑧ ⑨ ⑩ ⑪ ⑫ ⑬

① Nominal Model	② Threading Direction	⑤ Number of Turns (Turn-Row)	⑦ Product Code
S : Single nut D : Double nut O : OFF set double nut	R : Right L : Left	Turn : T : 1 A : 1.5 (or 1.7/1.8) B : 2.5/2.8	G : Ground F : Rolled
F : With flange C : Without flange	③ Nominal Diameter	C : 3.5 D : 4.8	⑧ Accuracy Grade
NI : NI type nut NU : NU type nut H : H type nut	Unit : mm	ex : (2.5 × 2 = B2)	C0, C1, C2, C3, C5, C7, C10
A : A type nut NH : NH nut (A solution for slide table) Y : Y type nut V : V type nut U : DIN nut M : M type nut K : K type nut	④ Lead	⑥ Flange Type	⑨ Overall Length of Shaft
	Unit : mm	N : Not cutting S : Single cutting D : Double cutting	Unit : mm

⑩ Axial Clearance and Preload Value	⑪ Number of Nut
P0, P1, P2, P3, P4	(Leave blank if only one nut is required) Ex : Install two nuts on a shaft B2

⑫ Nut Surface Treatment	⑬ Shaft Surface Treatment
S : Standard B1 : Black Oxidation N1 : Hard Chrome Plating P : Phosphating N3 : Nickel Plating N4 : Raydent N5 : Chrome Plating	S : Standard B1 : Black Oxidation N1 : Hard Chrome Plating P : Phosphating N3 : Nickel Plating N4 : Raydent N5 : Chrome Plating

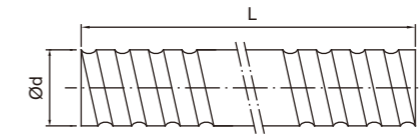

Fig 3.7.1 Screw Shaft Nominal Diameter

Table 3.7.1 Ground Ball Screw Specifications Ø4~32

Ød	Model No.		Accuracy Grade	Threading Direction		Number of Grooves	Standard Code of Shaft	Type of Nut
	l	Da		R : Right	L : Left			
4	1	0.8	C7, C5, C3		R	1	SCR00401	K
6	1	0.8	C7, C5, C3		R	1	SCR00601	K
8	1	0.8	C7, C5, C3		R/L	1	SCR00801	K
	2	1.2	C7, C5, C3		R/L	1	SCR00802	K
10	2.5	1.2	C7, C5, C3		R	1	SCR0082.5	K, BSH
	2	1.2	C7, C5, C3		R/L	1	SCR01002	K, BSH
12	4	2	C7, C5, C3		R	1	SCR01004	K, BSH
	2	1.2	C7, C5, C3		R/L	1	SCR01202	K
14	4	2.5	C7, C5, C3		R	1	SCR01204	U, BSH
	5	2.5	C7, C5, C3		R	1	SCR01205-A	V, U, BSH, H, A
	10	2.5	C7, C5, C3		R	2	SCR01210-B	V
15	2	1.2	C7, C5, C3		R/L	1	SCR01402	K
	4	2.5	C7, C5, C3		R	1	SCR01404	BSH
16	10	3.175	C7, C5, C3		R	1	SCR01510	V
	20	3.175	C7, C5, C3		R	1	SCR01520	V
20	2	1.2	C7, C5, C3		R/L	1	SCR01602	K
	4	2.381	C7, C5, C3		R	1	SCR01604(N)	V, I, U, BSH
	5	3.175	C7, C5, C3		R/L	1	SCR01605	V, NI, NU, BSH
	10	3.175	C7, C5, C3		R/L	2	SCR01610	V, NI, NU, BSH
	16	2.778	C7, C5, C3		R	2	SCR01616	Y
	32	2.778	C7, C5, C3		R	2	SCR01632	Y
25	2	1.2	C7, C5, C3		R	1	SCR02002	K
	4	2.381	C7, C5, C3		R	1	SCR02004(N)	V, I, U
	5	3.175	C7, C5, C3		R/L	1	SCR02005	V, NI, NU, BSH, H, A
	10	3.969	C7, C5, C3		R	1	SCR02010	V
	20	3.175	C7, C5, C3		R	2	SCR02020	V, Y, H, A
32	40	3.175	C7, C5, C3		R	2	SCR02040	Y
	2	1.2	C7, C5, C3		R	1	SCR02502	K
	4	2.381	C7, C5, C3		R	1	SCR02504(N)	I, U
	5	3.175	C7, C5, C3		R/L	1	SCR02505	V, NI, NU, BSH, H, A
	6	3.969	C7, C5, C3		R	1	SCR02506	V, U
	8	4.762	C7, C5, C3		R	1	SCR02508	V, U
	10	4.762	C7, C5, C3		R/L	1	SCR02510-A	NI, NU, BSH
	10	6.35	C7, C5, C3		R	1	SCR02510-B	V
25	3.969	C7, C5, C3		R	2	SCR02525	Y	
50	3.969	C7, C5, C3		R	2	SCR02550	Y	
32	4	2.381	C7, C5, C3		R	1	SCR03204(N)	V, I, U
	5	3.175	C7, C5, C3		R/L	1	SCR03205	V, NI, NU, M, H, A
	6	3.969	C7, C5, C3		R	1	SCR03206	V, U
	8	4.762	C7, C5, C3		R	1	SCR03208	V, U
	10	6.35	C7, C5, C3		R/L	1	SCR03210	V, NI, NU
	20	6.35	C7, C5, C3		R	1	SCR03220	V
	32	4.762	C7, C5, C3		R	2	SCR03232	Y
	64	4.762	C7, C5, C3		R	2	SCR03264	Y

3-7 Nominal Model Code of Ball Screw

Table 3.7.2 Standard Specifications Ø40~80 Unit : mm

Model No.	Accuracy Grade	Threading Direction R : Right L : Left	Number of Grooves	Standard Code of Shaft	Type of Nut		
						Ød	l
40	5	3.175	C7, C5, C3	R / L	1	SCR04005	V, NI, NU, H, A
	6	3.969	C7, C5, C3	R	1	SCR04006	V, NU
	8	4.762	C7, C5, C3	R	1	SCR04008	V, NU
	10	6.35	C7, C5, C3	R / L	1	SCR04010	V, NI, NU
	20	6.35	C7, C5, C3	R	2	SCR04020	V
	40	6.35	C7, C5, C3	R	2	SCR04040	Y
	80	6.35	C7, C5, C3	R	2	SCR04080	Y
50	5	3.175	C7, C5, C3	R	1	SCR05005	V, H, A
	10	6.35	C7, C5, C3	R / L	1	SCR05010	V, NI, NU
	20	9.525	C7, C5, C3	R	1	SCR05020	V
	50	7.938	C7, C5, C3	R	2	SCR05050	Y
	100	7.938	C7, C5, C3	R	2	SCR050100	Y
63	10	6.35	C7, C5, C3	R	1	SCR06310	V, NI, NU
	20	9.525	C7, C5, C3	R	1	SCR06320	V, NU
80	10	6.35	C7, C5, C3	R	1	SCR08010	V, NI, NU
	20	9.525	C7, C5, C3	R	1	SCR08020	V, U

Table 3.7.3 H, A-type Specifications Ø16~50 Unit : mm

Model No.	Accuracy Grade	Threading Direction R : Right L : Left	Number of Grooves	Type-H Code of Shaft	Type of Nut		
						Ød	l
12	10	2.5	C7, C5, C3	R	1	SSR01210	H, A
16	5	2.778	C7, C5, C3	R	1	SSR01605	H, A
	10	2.778	C7, C5, C3	R	1	SSR01610	H, A
	16	2.778	C7, C5, C3	R	1	SSR01616	H, A
	20	2.778	C7, C5, C3	R	1	SSR01620	H, A
20	10	3.175	C7, C5, C3	R	1	SSR02010	H, A
25	10	3.175	C7, C5, C3	R	1	SSR02510	H, A
	25	3.175	C7, C5, C3	R	1	SSR02525	H, A
32	10	3.969	C7, C5, C3	R	1	SSR03210	H, A
	20	3.969	C7, C5, C3	R	1	SSR03220	H, A
	32	6.35	C7, C5, C3	R	1	SSR03232	H, A
40	10	6.35	C7, C5, C3	R	1	SSR04010	H, A
	20	6.35	C7, C5, C3	R	1	SSR04020	H, A
	40	6.35	C7, C5, C3	R	1	SSR04040	H, A
50	10	6.35	C7, C5, C3	R	1	SSR05010	H, A
	20	6.35	C7, C5, C3	R	1	SSR05020	H, A
	50	6.35	C7, C5, C3	R	1	SSR05050	H, A

※ The information is for specifications, if customized products are needed please contact LTROBOT.

3-8 Ground Ball Screw Series

3-8-1 LTROBOT Nut of Ground Ball Screw Type

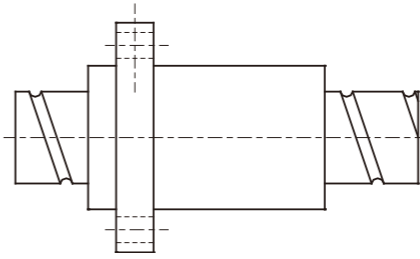
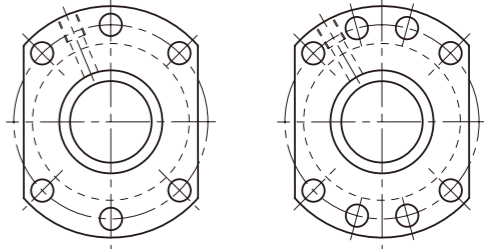
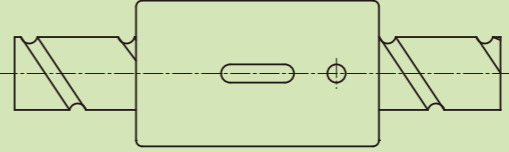
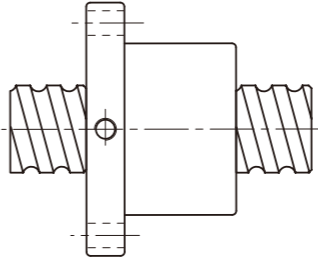
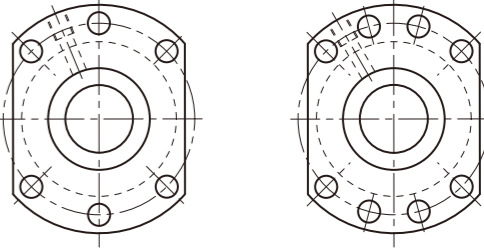
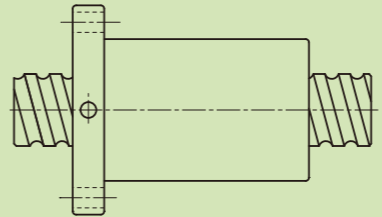
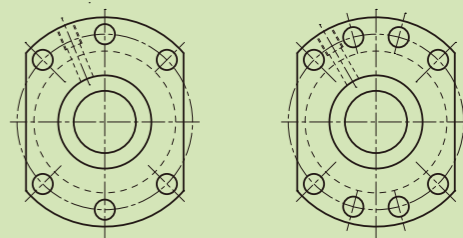
	Nut Type	Flange Type
NH/H/A (A solution for slide table/High Speed/Strong dust-proof type)	SFNH/SFH/SFA (DIN)  P57,58	 d≤32 d≥40
CNH (A solution for slide table)	SCNH  P59	No-Flange
NU/U (Strong dust-proof type)	SFNU/SFU (DIN)  P60	 d≤32 d≥40
OFU/U (OFF set double nut)	OFU/DFU (DIN)  P61	

	Nut Type	Flange Type
NI/I (Strong dust-proof type)	<p>SFNI/SFI</p> <p>P62</p>	
Σ (Design for Milling)	<p>SFM</p> <p>P62</p>	
OFI/I (OFF set double nut)	<p>OFI/DFI</p> <p>P63</p>	
Σ (Design for Milling)	<p>DFM</p> <p>P63</p>	

	Nut Type	Flange Type
∨ (High Load External Circulation type)	<p>SFV</p> <p>P64</p>	
OFV (OFF set double nut)	<p>OFV</p> <p>P65</p>	
∨ (High Load External Circulation type)	<p>DFV</p> <p>P65</p>	
∨ (High DM-N Rating)	<p>SFY</p> <p>P66</p>	

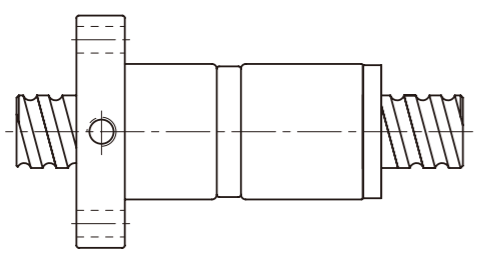
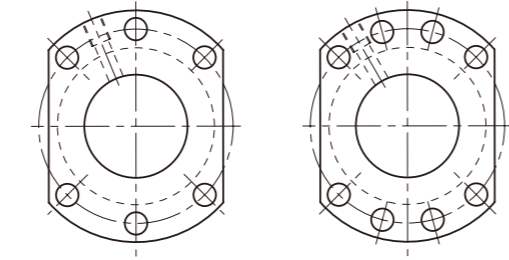
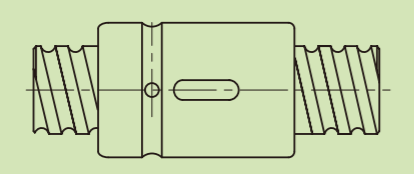
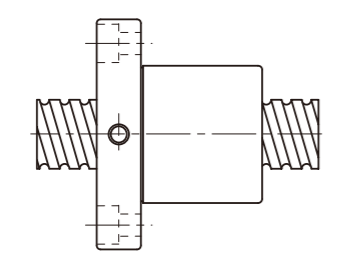
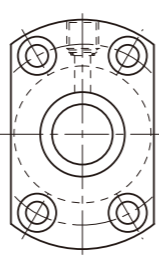
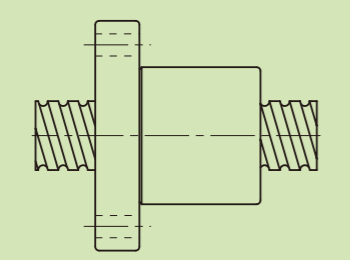
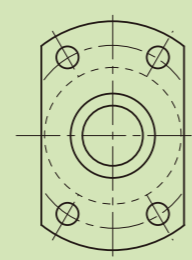
	Nut Type	Flange Type
<p>∞ (High Speed / Low Noise type)</p>	<p>DFS (DIN)</p>  <p>P67</p>	 <p>Model No. ≤3232 Model No. ≥4005</p>
<p>CNI/I (Standard)</p>	<p>SCNI/SCI</p>  <p>P68</p>	<p>No-Flange</p>
<p>≪ (Miniature type)</p>	<p>SFK</p>  <p>P69</p>	 <p>(SFK 01004) (SFK 02002) (SFK 02502)</p>
	<p>SFK</p>  <p>P69</p>	

	Nut Type	Flange Type
<p>BSH</p>	<p>BSH</p>  <p>d ≤ 12 d ≥ 14</p> <p>P70</p>	<p>No-Flange</p>

Table 8.3.1 Preload Chart

Preload	I, U, M-type	H, A-type	Y-type	V-type	BSH-type	K-type
P0						
P1	√	√	√	√	√	√
P2	√	√	√	√	√	
P3	√	√	√	√	√	
P4				√		

3-8 Ground Ball Screw Series

SFNH/SFH (DIN 69051 FORM B) Series Specifications

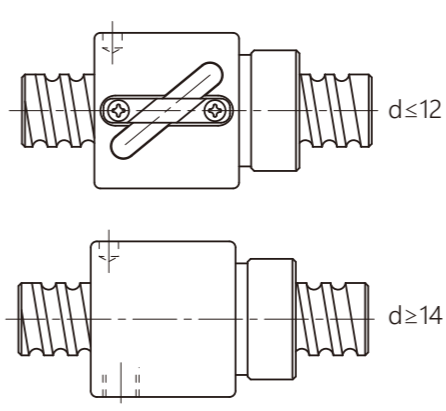
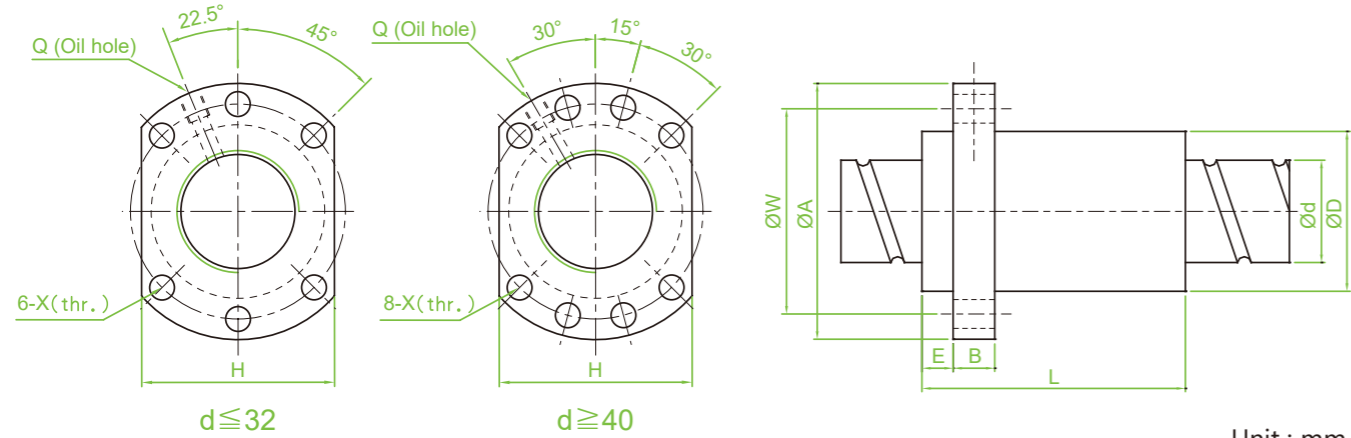

Unit : mm

Model No.	d	l	Da	Dimension										Load Rating		K kgf/μm
				D	A	E	B	L	W	H	X	Q	n	Ca (kgf)	Coa (kgf)	
SFH01205-2.8★	12	5	2.5	24	40	5	10	30	32	30	4.5		2.8x1	661	1316	19
SFH01210-2.8★		10	2.5	24	40	5	10	45	32	30	4.5		2.8x1	642	1287	19
SFH01605-3.8★	15	5	2.778	28	48	5	10	37	38	40	5.5	M6	3.8x1	1112	2507	30
SFH01610-2.8★		10	2.778	28	48	5	10	45	38	40	5.5	M6	2.8x1	839	1821	23
SFH01616-1.8★		16	2.778	28	48	5	10	45	38	40	5.5	M6	1.8x1	552	1137	14
SFH01616-2.8★		16	2.778	28	48	5	10	61	38	40	5.5	M6	2.8x1	808	1769	22
SFH01620-1.8★	20	2.778	28	48	7	10	58	38	40	5.5	M6	1.8x1	554	1170	14	
SFH02005-3.8★	20	5	3.175	36	58	7	10	37	47	44	6.6	M6	3.8x1	1484	3681	37
SFH02010-3.8★		10	3.175	36	58	7	10	55	47	44	6.6	M6	3.8x1	1516	3833	40
SFH02020-1.8★		20	3.175	36	58	7	10	54	47	44	6.6	M6	1.8x1	764	1758	19
SFH02020-2.8★		20	3.175	36	58	7	10	74	47	44	6.6	M6	2.8x1	1118	2734	29
SFH02505-3.8★	25	5	3.175	40	62	7	10	37	51	48	6.6	M6	3.8x1	1650	4658	43
SFH02510-3.8★		10	3.175	40	62	7	12	55	51	48	6.6	M6	3.8x1	1638	4633	45
SFH02525-1.8★		25	3.175	40	62	7	12	64	51	48	6.6	M6	1.8x1	843	2199	22
SFH02525-2.8★		25	3.175	40	62	7	12	89	51	48	6.6	M6	2.8x1	1232	3421	34
SFH03205-3.8	32	5	3.175	50	80	9	12	37	65	62	9	M6	3.8x1	1839	6026	51
SFH03210-3.8	31	10	3.969	50	80	9	12	57	65	62	9	M6	3.8x1	2460	7255	55
SFH03220-2.8		20	3.969	50	80	9	12	76	65	62	9	M6	2.8x1	1907	5482	43
SFH03232-1.8		32	3.969	50	80	9	12	80	65	62	9	M6	1.8x1	1257	3426	27
SFH03232-2.8		32	3.969	50	80	9	12	112	65	62	9	M6	2.8x1	1838	5329	42
SFH04005-3.8	40	5	3.175	63	93	9	15	42	78	70	9	M8	3.8x1	2018	7589	60
SFH04010-3.8	38	10	6.35	63	93	9	14	60	78	70	9	M8	3.8x1	5035	13943	67
SFH04020-2.8		20	6.35	63	93	9	14	80	78	70	9	M8	2.8x1	3959	10715	54
SFH04040-1.8		40	6.35	63	93	9	14	98	78	70	9	M8	1.8x1	2585	6648	34
SFH04040-2.8		40	6.35	63	93	9	14	138	78	70	9	M8	2.8x1	3780	10341	52
SFH05005-3.8	50	5	3.175	75	110	10.5	15	42	93	85	11	M8	3.8x1	2207	9542	68
SFH05010-3.8	48	10	6.35	75	110	10.5	18	60	93	85	11	M8	3.8x1	5638	17852	79
SFH05020-3.8		20	6.35	75	110	10.5	18	100	93	85	11	M8	3.8x1	5749	18485	87
SFH05050-1.8		50	6.35	75	110	10.5	18	120	93	85	11	M8	1.8x1	2946	8749	42
SFH05050-2.8		50	6.35	75	110	10.5	18	170	93	85	11	M8	2.8x1	4308	13610	65

※ ★ Actuator type available (SFNH series).

SFA Series Specifications

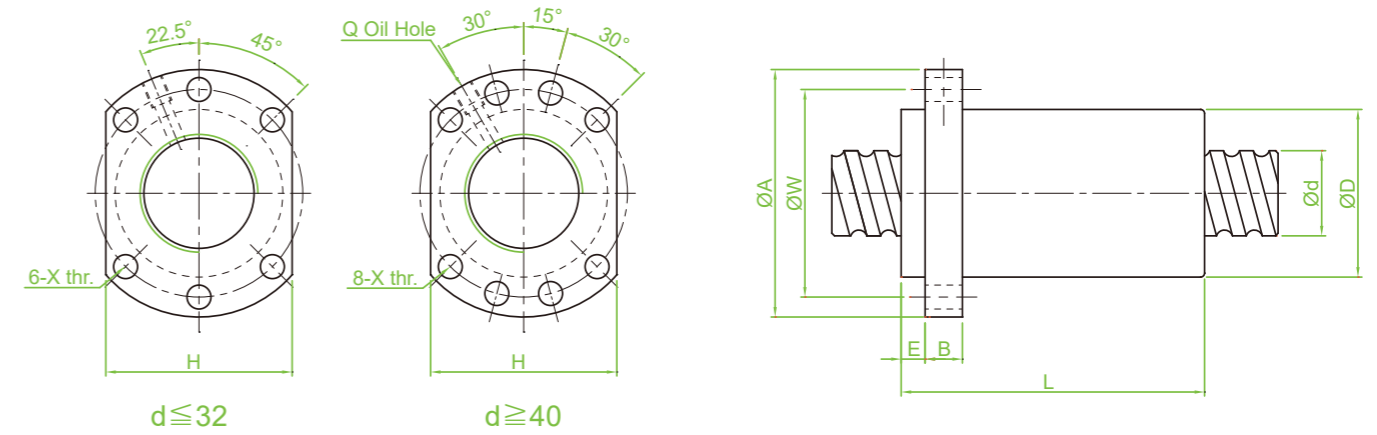

Unit : mm

Model No.	d	l	Da	Dimension										Load Rating		K kgf/μm
				D	A	E	B	L	W	H	X	Q	n	Ca (kgf)	Coa (kgf)	
SFA1205-2.8★	12	5	2.5	24	40	5	10	30	32	30	4.5		2.8x1	661	1316	19
SFA1210-2.8★		10	2.5	24	40	5	10	42	32	30	4.5		2.8x1	642	1287	19
SFA1605-3.8★	15	5	2.778	28	48	5	10	31	38	40	5.5	M6	3.8x1	1112	2507	30
SFA1610-2.8★		10	2.778	28	48	5	10	42	38	40	5.5	M6	2.8x1	839	1821	23
SFA1616-1.8★		16	2.778	28	48	5	10	43	38	40	5.5	M6	1.8x1	552	1137	14
SFA1616-2.8★		16	2.778	28	48	5	10	59	38	40	5.5	M6	2.8x1	808	1769	22
SFA1620-1.8★	20	2.778	28	48	5	10	50	38	40	5.5	M6	1.8x1	554	1170	14	
SFA1630-1.8★	30	2.778	28	48	7	10	70	38	40	5.5	M6	1.8x1	534	1195	14	
SFA2005-3.8★	20	5	3.175	36	58	7	10	33	47	44	6.6	M6	3.8x1	1484	3681	37
SFA2010-3.8★		10	3.175	36	58	7	10	52	47	44	6.6	M6	3.8x1	1516	3833	40
SFA2020-1.8★		20	3.175	36	58	7	10	52	47	44	6.6	M6	1.8x1	764	1758	19
SFA2020-2.8★		20	3.175	36	58	7	10	72	47	44	6.6	M6	2.8x1	1118	2734	29
SFA2505-3.8★	25	5	3.175	40	62	7	10	33	51	48	6.6	M6	3.8x1	1650	4658	43
SFA2510-3.8★		10	3.175	40	62	7	12	52	51	48	6.6	M6	3.8x1	1638	4633	45
SFA2525-1.8★		25	3.175	40	62	7	12	60	51	48	6.6	M6	1.8x1	843	2199	22
SFA2525-2.8★		25	3.175	40	62	7	12	85	51	48	6.6	M6	2.8x1	1232	3421	34
SFA3205-3.8	32	5	3.175	50	80	9	12	35	65	62	9	M6	3.8x1	1839	6026	51
SFA3210-3.8	31	10	3.969	50	80	9	12	53	65	62	9	M6	3.8x1	2460	7255	55
SFA3220-2.8		20	3.969	50	80	9	12	72	65	62	9	M6	2.8x1	1907	5482	43
SFA3232-1.8		32	3.969	50	80	9	12	78	65	62	9	M6	1.8x1	1257	3426	27
SFA3232-2.8		32	3.969	50	80	9	12	110	65	62	9	M6	2.8x1	1838	5329	42
SFA4005-3.8	40	5	3.175	63	93	9	14	39	78	70	9	M8	3.8x1	2018	7589	60
SFA4010-3.8	38	10	6.35	63	93	9	14	57	78	70	9	M8	3.8x1	5035	13943	67
SFA4020-2.8		20	6.35	63	93	9	14	78	78	70	9	M8	2.8x1	3959	10715	54
SFA4040-1.8		40	6.35	63	93	9	14	96	78	70	9	M8	1.8x1	2585	6648	34
SFA4040-2.8		40	6.35	63	93	9	14	136	78	70	9	M8	2.8x1	3780	10341	52
SFA5005-3.8	50	5	3.175	75	110	10.5	15	42	93	85	11	M8	3.8x1	2207	9542	68
SFA5010-3.8	48	10	6.35	75	110	10.5	18	57	93	85	11	M8	3.8x1	5638	17852	79
SFA5020-3.8		20	6.35	75	110	10.5	18	98	93	85	11	M8	3.8x1	5749	18485	87
SFA5050-1.8		50	6.35	75	110	10.5	18	117	93	85	11	M8	1.8x1	2946	8749	42
SFA5050-2.8		50	6.35	75	110	10.5	18	167	93	85	11	M8	2.8x1	4308	13610	65

※ ★ Actuator type available.

3-8 Ground Ball Screw Series

SCNH Series Specifications

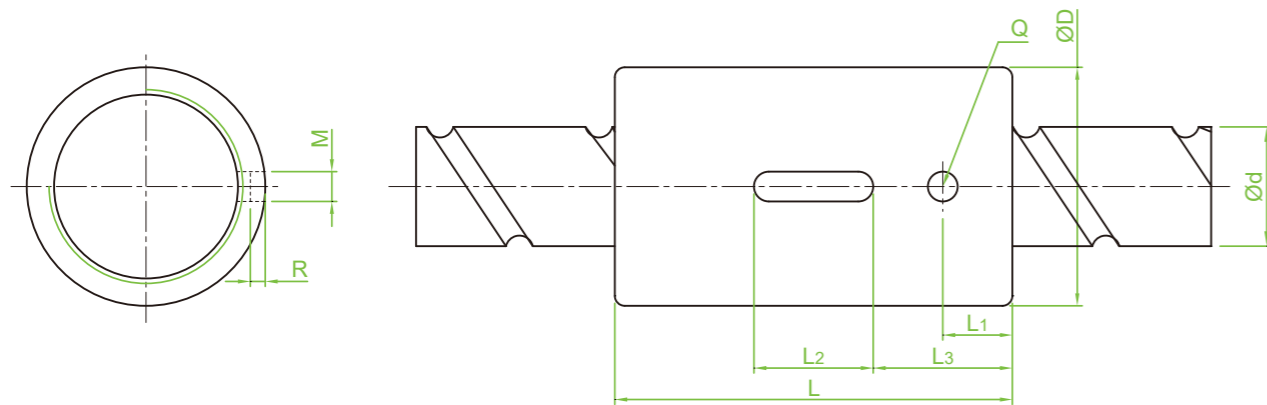

Unit : mm

Model No.	d	l	Da	Dimension									Load Rating		K kgf/μm
				D	L	L1	L2	L3	M	R	Q	n	Ca (kgf)	Coa (kgf)	
SCNH01205-4.8	12	5	2.5	24	40	7	12	14	3	1.5	3	4.8x1	1011	2105	34
SCNH01210-2.8		10	2.5	24	45	8	15	15	3	1.5	3	2.8x1	642	1287	19
XCNH01210-1.8		10	2.5	24	40	10.5	12	14	3	1.5	3	1.8x1	439	827	33
SCNH01605-5.8	15	5	2.778	28	45	7	20	12.5	5	3	3	5.8x1	1599	3827	49
SCNH01610-2.8		10	2.778	28	45	7	20	12.5	5	3	3	2.8x1	839	1821	23
SCNH01616-1.8		16	2.778	28	45	7	20	12.5	5	3	3	1.8x1	552	1137	18
SCNH01620-1.8		20	2.778	28	58	10	20	19	5	3	3	1.8x1	554	1170	14
SCNH02005-5.8	20	5	3.175	36	47	8	20	13.5	5	3	3	5.8x1	2134	5619	60
SCNH02010-3.8		10	3.175	36	55	8	20	17.5	5	3	3	3.8x1	1516	3833	40
SCNH02020-1.8		20	3.175	36	55	8	20	17.5	5	3	3	1.8x1	764	1758	19

SFNU/SFU (DIN 69051 FORM B) Series Specifications

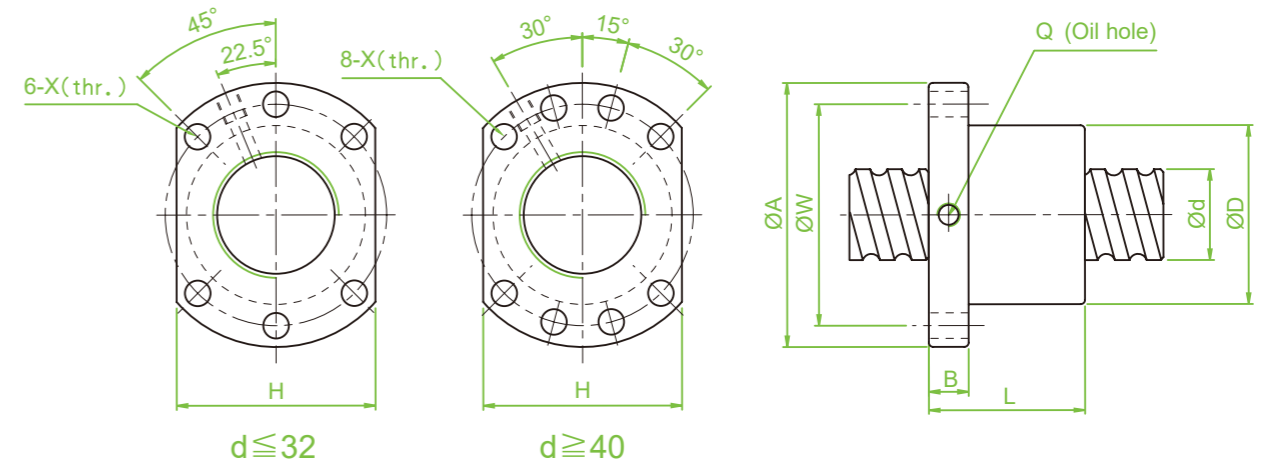

Unit : mm

Model No.	d	l	Da	Dimension									Load Rating		K kgf/μm
				D	A	B	L	W	H	X	Q	n	Ca (kgf)	Coa (kgf)	
SFNU01605-4*	16	5	3.175	28	48	10	45	38	40	5.5	M6	1x4	1380	3052	32
SFNU01610-3*		10	3.175	28	48	10	57	38	40	5.5	M6	1x3	1103	2401	26
SFNU02005-4*	20	5	3.175	36	58	10	51	47	44	6.6	M6	1x4	1551	3875	39
SFNU02505-4*		5	3.175	40	62	10	51	51	48	6.6	M6	1x4	1724	4904	45
SFNU02510-4*	25	10	4.762	40	62	12	80	51	48	6.6	M6	1x4	2954	7295	50
SFNU03205-4*		5	3.175	50	80	12	52	65	62	9	M6	1x4	1922	6343	54
SFNU03210-4*	32	10	6.35	50	80	12	85	65	62	9	M6	1x4	4805	12208	61
SFNU04005-4*		5	3.175	63	93	14	55	78	70	9	M8	1x4	2110	7988	63
SFNU04010-4*	40	10	6.35	63	93	14	88	78	70	9	M8	1x4	5399	15500	73
SFNU05010-4*		50	6.35	75	110	16	88	93	85	11	M8	1x4	6004	19614	85
SFNU06310-4	63	10	6.35	90	125	18	93	108	95	11	M8	1x4	6719	25358	99
SFNU08010-4	80	10	6.35	105	145	20	93	125	110	13.5	M8	1x4	7346	31953	109
SFU01204-4	12	4	2.5	24	40	10	40	32	30	4.5		1x4	902	1884	26
SFU01604-4	16	4	2.381	28	48	10	40	38	40	5.5	M6	1x4	973	2406	32
SFU02004-4	20	4	2.381	36	58	10	42	47	44	6.6	M6	1x4	1066	2987	38
SFU02504-4	25	4	2.381	40	62	10	42	51	48	6.6	M6	1x4	1180	3795	43
SFU02506-4		6	3.969	40	62	10	54	51	48	6.6	M6	1x4	2318	6057	47
SFU02508-4		8	4.762	40	62	10	63	51	48	6.6	M6	1x4	2963	7313	49
SFU03204-4	32	4	2.381	50	80	12	44	65	62	9	M6	1x4	1296	4838	51
SFU03206-4		6	3.969	50	80	12	57	65	62	9	M6	1x4	2632	7979	57
SFU03208-4		8	4.762	50	80	12	65	65	62	9	M6	1x4	3387	9622	60
SFU04006-4	40	6	3.969	63	93	14	60	78	70	9	M6	1x4	2873	9913	66
SFU04008-4		8	4.762	63	93	14	67	78	70	9	M6	1x4	3712	11947	70
SFU05020-4	50	20	7.144	75	110	16	138	93	85	11	M8	1x4	7142	22588	94
SFU06320-4	63	20	9.525	95	135	20	149	115	100	13.5	M8	1x4	11444	36653	112
SFU08020-4	80	20	9.525	125	165	25	154	145	130	13.5	M8	1x4	12911	47747	138
SFU10020-4	100	20	9.525	150	202	30	180	170	155	17.5	M8	1x4	14303	60698	162

※ ☆ Left helix available

3-8 Ground Ball Screw Series

OFU/DFU (DIN 69051 FORM B) Series Specifications

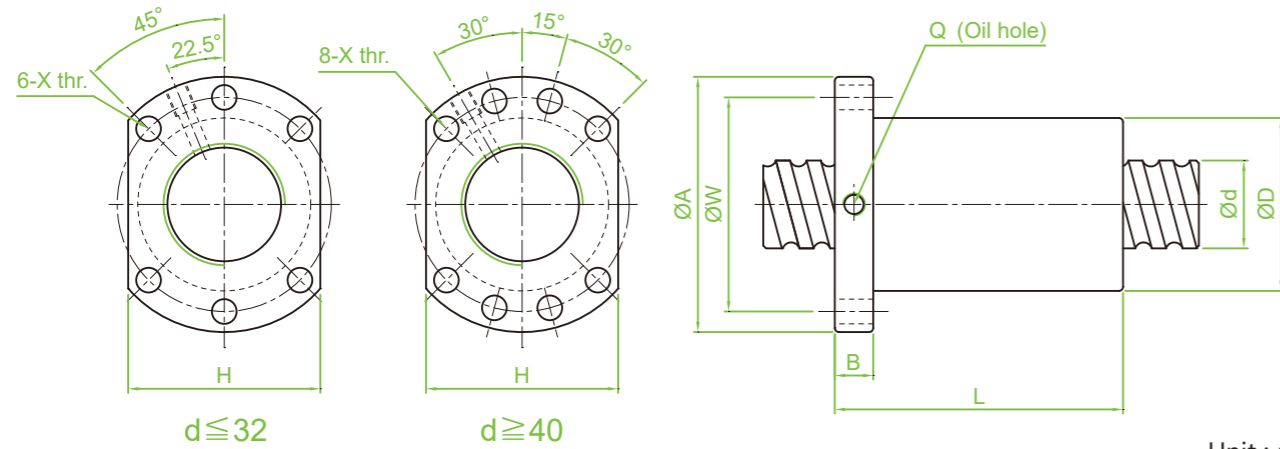

Model No.	d	l	Da	Dimension									Load Rating		K kgf/ μ m
				D	A	B	L	W	H	X	Q	n	Ca (kgf)	Coa (kgf)	
OFU01605-4	16	5	3.175	28	48	10	75	38	40	5.5	M6	1x8	1380	3052	44
OFU02005-4	20	5	3.175	36	58	10	85	47	44	6.6	M6	1x8	1551	3875	53
OFU02505-4	25	5	3.175	40	62	10	86	51	48	6.6	M6	1x8	1724	4904	62
OFU02510-4		10	4.762	40	62	12	130	51	48	6.6	M6	1x8	2954	7295	67
OFU03205-4	32	5	3.175	50	80	12	87	65	62	9	M6	1x8	1922	6343	74
OFU03210-4		10	6.35	50	80	12	145	65	62	9	M6	1x8	4805	12208	82
OFU04005-4	40	5	3.175	63	93	14	90	78	70	9	M8	1x8	2110	7988	87
OFU04010-4		10	6.35	63	93	14	148	78	70	9	M8	1x8	5399	15500	99
OFU05010-4	50	10	6.35	75	110	16	148	93	85	11	M8	1x8	6004	19614	117
OFU06310-4	63	10	6.35	90	125	18	153	108	95	11	M8	1x8	6719	25358	139
OFU08010-4	80	10	6.35	105	145	20	153	125	110	13.5	M8	1x8	7346	31953	156
DFU01604-4	16	4	2.381	28	48	10	80	38	40	5.5	M6	1x4	973	2406	43
DFU02004-4	20	4	2.381	36	58	10	80	47	44	6.6	M6	1x4	1066	2987	51
DFU02504-4	25	4	2.381	40	62	10	80	51	48	6.6	M6	1x4	1180	3795	60
DFU02506-4		6	3.969	40	62	10	105	51	48	6.6	M6	1x4	2318	6057	64
DFU02508-4		8	4.762	40	62	10	120	51	48	6.6	M6	1x4	2963	7313	67
DFU03204-4	32	4	2.381	50	80	12	80	65	62	9	M6	1x4	1296	4838	71
DFU03206-4		6	3.969	50	80	12	105	65	62	9	M6	1x4	2632	7979	78
DFU03208-4		8	4.762	50	80	12	122	65	62	9	M6	1x4	3387	9622	82
DFU04006-4	40	6	3.969	63	93	14	108	78	70	9	M6	1x4	2873	9913	91
DFU04008-4		8	4.762	63	93	14	132	78	70	9	M6	1x4	3712	11947	96
DFU05020-4	50	20	7.144	75	110	16	280	93	85	11	M8	1x4	7142	22588	126
DFU06320-4	63	20	9.525	95	135	20	290	115	100	13.5	M8	1x4	11444	36653	152
DFU08020-4	80	20	9.525	125	165	25	295	145	130	13.5	M8	1x4	12911	47747	187
DFU10020-4	100	20	9.525	150	202	30	340	170	155	17.5	M8	1x4	14303	60698	222

Unit : mm

SFNI/SFI Series Specifications

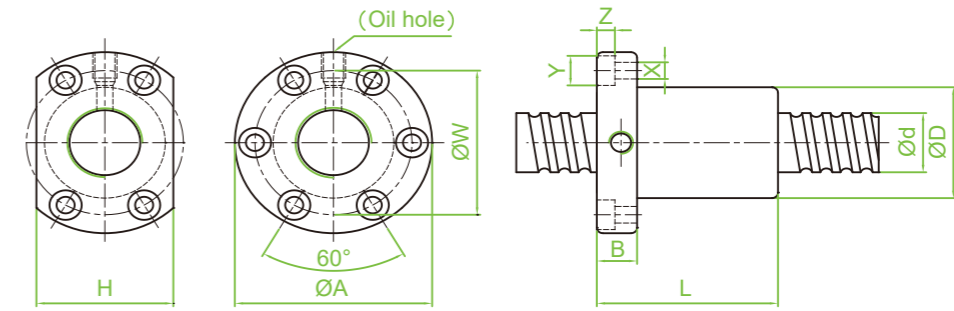

Unit : mm

Model No.	d	l	Da	Dimension											Load Rating		K kgf/ μ m
				D	A	B	L	W	H	X	Y	Z	Q	n	Ca (kgf)	Coa (kgf)	
SFNI01605-4*	16	5	3.175	30	49	10	45	39	34	4.5	8	4.5	M6	1x4	1380	3052	33
SFNI01610-3*		10	3.175	34	58	10	57	45	34	5.5	9.5	5.5	M6	1x3	1103	2401	27
SFNI02005-4*	20	5	3.175	34	57	11	51	45	40	5.5	9.5	5.5	M6	1x4	1551	3875	39
SFNI02505-4*		5	3.175	40	63	11	51	51	46	5.5	9.5	5.5	M8	1x4	1724	4904	45
SFNI02510-4*	25	10	4.762	46	72	12	80	58	52	6.5	11	6.5	M6	1x4	2954	7295	51
SFNI03205-4*		5	3.175	46	72	12	52	58	52	6.5	11	6.5	M8	1x4	1922	6343	52
SFNI03210-4*	32	10	6.35	54	88	15	85	70	62	9	14	8.5	M8	1x4	4805	12208	62
SFNI04005-4*		5	3.175	56	90	15	55	72	64	9	14	8.5	M8	1x4	2110	7988	59
SFNI04010-4*	40	10	6.35	62	104	18	88	82	70	11	17.5	11	M8	1x4	5399	15500	72
SFNI05010-4*		50	10	6.35	72	114	18	88	92	82	11	17.5	11	M8	1x4	6004	19614
SFNI06310-4	63	10	6.35	85	131	22	93	107	95	14	20	13	M8	1x4	6719	25358	95
SFNI08010-4	80	10	6.35	105	150	22	93	127	115	14	20	13	M8	1x4	7346	31953	109
SFI01604-4	16	4	2.381	30	49	10	45	39	34	4.5	8	4.5	M6	1x4	973	2406	32
SFI02004-4		4	2.381	34	57	11	46	45	40	5.5	9.5	5.5	M6	1x4	1066	2987	37
SFI0205T-4		5.08	3.175	34	57	11	51	45	40	5.5	9.5	5.5	M6	1x4	1550	3875	39
SFI02504-4*	25	4	2.381	40	63	11	46	51	46	5.5	9.5	5.5	M6	1x4	1180	3795	43
SFI0255T-4		5.08	3.175	40	63	11	51	51	46	5.5	9.5	5.5	M8	1x4	1724	4903	45
SFI03204-4	32	4	2.381	46	72	12	47	58	52	6.5	11	6.5	M6	1x4	1296	4838	49

SFM Series Specifications

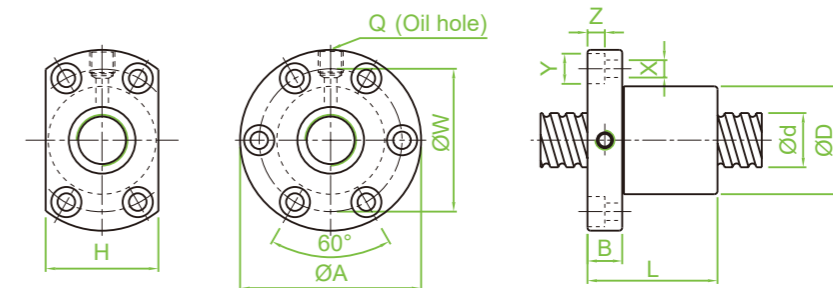

Unit : mm

Model No.	d	l	Da	Dimension											Load Rating		K kgf/ μ m
				D	A	B	L	W	H	X	Y	Z	Q	n	Ca (kgf)	Coa (kgf)	
SFM03205-4*	32	5	3.175	48	74	12	52	60	60	6.5	11	6.5	M8	1x4	1922	6343	53
SFM0325T-4*		5.08	3.175	48	74	12	53	60	60	6.5	11	6.5	M8	1x4	1922	6343	53

※ Left helix available

3-8 Ground Ball Screw Series

OFI/DFI Series Specifications

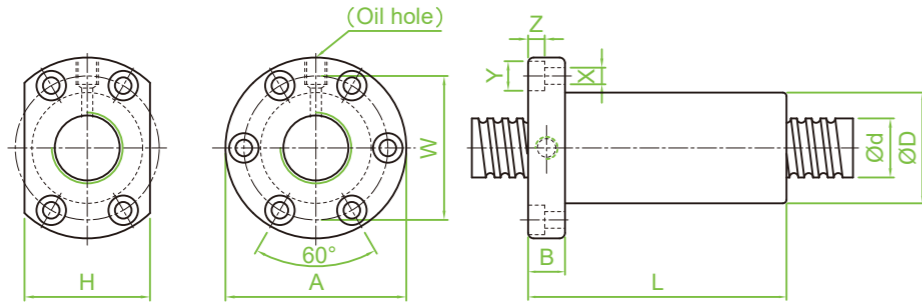

Unit : mm

ModelNo.	d	l	Da	Dimension											LoadRating		K kgf/μm
				D	A	B	L	W	H	X	Y	Z	Q	n	Ca (kgf)	Coa (kgf)	
OFI01605-4	16	5	3.175	30	49	10	75	39	34	4.5	8	4.5	M6	1x8	1380	3052	44
OFI02005-4	20	5	3.175	34	57	11	85	45	40	5.5	9.5	5.5	M6	1x8	1551	3875	52
OFI02505-4	25	5	3.175	40	63	11	86	51	46	5.5	9.5	5.5	M8	1x8	1724	4904	62
OFI02510-4		10	4.762	46	72	12	130	58	52	6.5	11	6.5	M6	1x8	2954	7295	68
OFI03205-4	32	5	3.175	46	72	12	87	58	52	6.5	11	6.5	M8	1x8	1922	6343	72
OFI03210-4		10	6.35	54	88	15	145	70	62	9	14	8.5	M8	1x8	4805	12208	83
OFI04005-4	40	5	3.175	56	90	15	90	72	64	9	14	8.5	M8	1x8	2110	7988	84
OFI04010-4		10	6.35	62	104	18	148	82	70	11	17.5	11	M8	1x8	5399	15500	99
OFI05010-4	50	10	6.35	72	114	18	148	92	82	11	17.5	11	M8	1x8	6004	19614	115
OFI06310-4	63	10	6.35	85	131	22	153	107	95	14	20	13	M8	1x8	6719	25358	135
OFI08010-4	80	10	6.35	105	150	22	153	127	115	14	20	13	M8	1x8	7346	31953	156
DFI01604-4	16	4	2.381	30	49	10	80	39	34	4.5	8	4.5	M6	1x4	973	2406	44
DFI02004-4	20	4	2.381	34	57	11	80	45	40	5.5	9.5	5.5	M6	1x4	1066	2987	51
DFI02504-4	25	4	2.381	40	63	11	80	51	46	5.5	9.5	5.5	M6	1x4	1180	3795	60
DFI0255T-4		5.08	3.175	40	63	11	101	51	46	5.5	9.5	5.5	M8	1x4	1724	4903	62
DFI03204-4	32	4	2.381	46	72	12	80	58	52	6.5	11	6.5	M6	1x4	1296	4838	69
DFI0325T-4		5.08	3.175	46	72	12	102	58	52	6.5	11	6.5	M8	1x4	1922	6343	72

DFM Series Specifications

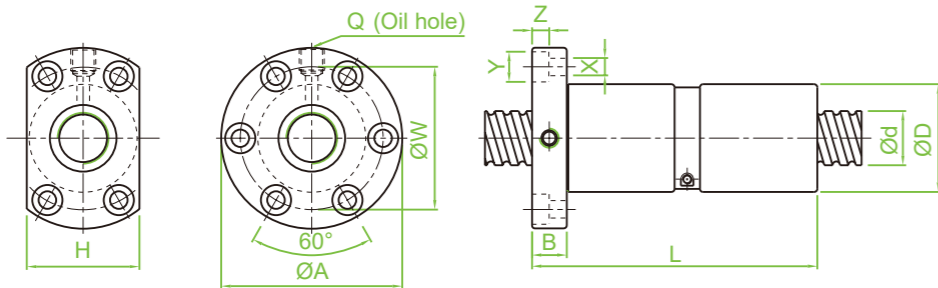

Unit : mm

Model No.	d	l	Da	Dimension											Load Rating		K kgf/μm
				D	A	B	L	W	H	X	Y	Z	Q	n	Ca (kgf)	Coa (kgf)	
DFM03205-4*	32	5	3.175	48	74	12	102	60	60	6.5	11	6.5	M8	1x4	1922	6343	73
DFM0325T-4*		5.08	3.175	48	74	12	104	60	60	6.5	11	6.5	M8	1x4	1922	6343	73

Note : For double ball screw nut order, please contact **LTROBOT** in advance. ※ ☆ Left helix available

SFV Series Specifications

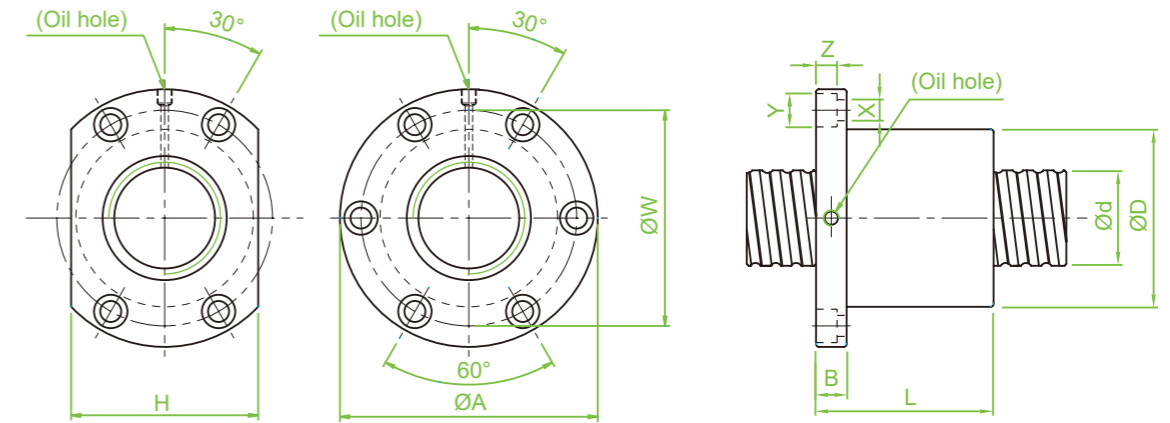

Unit : mm

Model No.	d	l	Da	Dimension											Load Rating		K kgf/μm
				D	A	B	L	W	H	X	Y	Z	Q	n	Ca (kgf)	Coa (kgf)	
SFV01205-2.8	12	5	2.5	30	50	10	42	40	32	4.5	8	4.5	M6	2.8x1	661	1316	19
SFV01210-2.7		10	2.5	30	50	10	53	40	32	4.5	8	4.5	M6	2.7x1	623	1241	18
SFV01510-2.7	15	10	3.175	34	58	10	57	45	34	5.5	9.5	5.5	M6	2.7x1	972	2020	23
SFV01604-3.8	16	4	2.381	34	57	11	45	45	34	5.5	9.5	5.5	M6	3.8x1	931	2285	31
SFV01605-4.8		5	3.175	40	63	11	58	51	42	5.5	9.5	5.5	M6	4.8x1	1614	3662	40
SFV01610-2.7	10	3.175	40	63	11	56	51	42	5.5	9.5	5.5	M6	2.7x1	1008	2161	24	
SFV02004-4.8	20	4	2.381	40	60	10	50	50	40	4.5	8	4	M6	4.8x1	1247	3584	45
SFV02005-4.8		5	3.175	44	67	11	57	55	52	5.5	9.5	5.5	M6	4.8x1	1814	4650	47
SFV02010-2.7	10	3.969	46	74	13	57	59	46	6.6	11	6.5	M6	2.7x1	1518	3398	30	
SFV02020-1.8	20	3.175	46	74	13	70	59	46	6.6	11	6.5	M6	1.8x1	764	1758	19	
SFV02505-4.8	25	5	3.175	50	73	11	55	61	52	5.5	9.5	5.5	M8	4.8x1	2017	5884	56
SFV02506-4.8		6	3.969	53	76	11	62	64	58	5.5	9.5	5.5	M6	4.8x1	2711	7268	58
SFV02508-4.8	8	4.762	56	85	13	70	71	64	6.5	11	6.5	M6	4.8x1	3466	8776	61	
SFV02510-2.7	10	6.35	68	102	15	70	84	82	9	14	8.5	M8	2.7x1	3040	6547	37	
SFV02525-1.8	25	3.175	50	73	13	83	61	52	5.5	9.5	5.5	M8	1.8x1	843	2199	22	
SFV03204-4.8	32	4	2.381	54	81	12	50	67	64	6.6	11	6.5	M6	4.8x1	1517	5806	62
SFV03205-4.8		5	3.175	58	85	12	56	71	64	6.6	11	6.5	M8	4.8x1	2249	7612	66
SFV03206-4.8	6	3.969	62	89	12	60	75	68	6.6	11	6.5	M8	4.8x1	3079	9575	70	
SFV03208-4.8	8	4.762	66	100	15	75	82	76	9	14	8.5	M8	4.8x1	3962	11547	74	
SFV03210-4.8	10	6.35	74	108	15	96	90	82	9	14	9	M8	4.8x1	5620	14649	76	
SFV03220-2.7	20	6.35	74	108	16	100	90	82	9	14	8.5	M8	2.7x1	3509	8644	46	
SFV04005-4.8	40	5	3.175	67	101	15	59	83	72	9	14	8.5	M8	4.8x1	2468	9586	76
SFV04010-4.8		10	6.35	82	124	18	100	102	94	11	17.5	11	M8	4.8x1	6316	18600	90
SFV04020-2.7	20	6.35	82	124	18	100	102	90	11	17.5	11	M8	2.7x1	3935	10893	56	
SFV05005-4.8	50	5	3.175	80	114	15	60	96	82	9	14	8.5	M8	4.8x1	2698	12053	87
SFV05010-4.8		10	6.35	93	135	16	93	113	98	11	17.5	11	M8	4.8x1	7023	23537	106
SFV05020-2.7	20	9.525	105	152	28	121	128	110	14	20	13	M8	2.7x1	7336	19700	68	
SFV06310-4.8	63	10	6.35	108	154	22	105	130	110	14	20	13	M8	4.8x1	7860	30430	126
SFV06320-2.7		20	9.525	122	180	28	120	150	130	18	26	17.5	M8	2.7x1	8162	24741	80
SFV08010-4.8	80	10	6.35	130	176	22	105	152	132	14	20	13	M8	4.8x1	8593	38344	145
SFV08020-4.8		20	9.525	143	204	28	180	172	148	18	26	18	M8	4.8x1	15103	57296	168
SFV08020-7.6	20	9.525	143	204	28	240	172	148	18	26	18	M8	3.8x2	22423	90719	260	

3-8 Ground Ball Screw Series

OFV/DFV Series Specifications

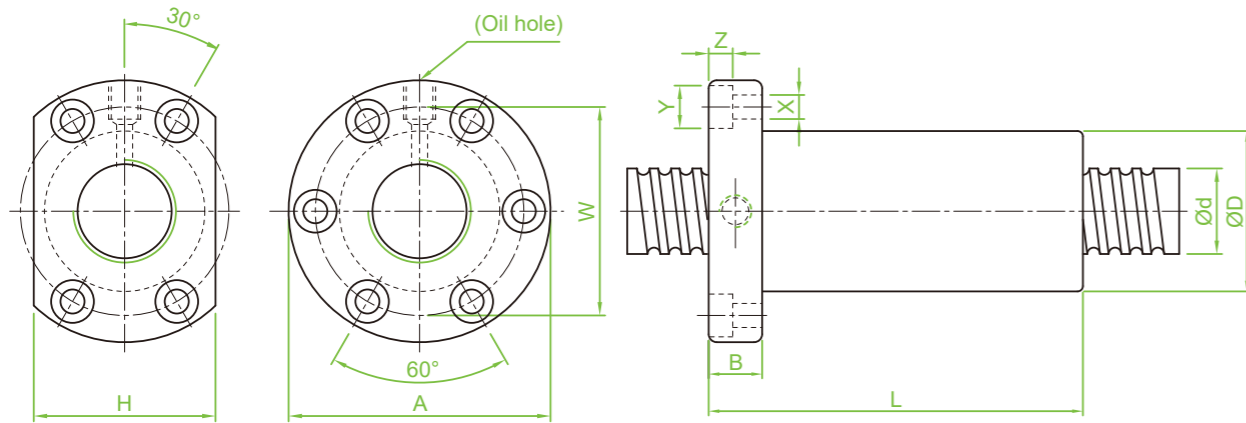

Unit : mm

Model No.	d	l	Da	Dimension											Load Rating		K kgf/µm
				D	A	B	L	W	H	X	Y	Z	Q	n	Ca (kgf)	Coa (kgf)	
OFV01605-4.8	16	5	3.175	40	63	11	100	51	42	5.5	9.5	5.5	M6	4.8x2	1614	3662	53
OFV02005-4.8	20	5	3.175	44	67	11	102.5	55	52	5.5	9.5	5.5	M6	4.8x2	1814	4650	63
OFV02505-4.8	25	5	3.175	50	73	11	96	61	52	5.5	9.5	5.5	M8	4.8x2	2017	5884	75
OFV03205-4.8	32	5	3.175	58	85	12	98	71	64	6.6	11	6.5	M8	4.8x2	2249	7612	90
OFV03210-4.8		10	6.35	74	108	15	166	90	82	9	14	9	M8	4.8x2	5620	14649	101
OFV04005-4.8	40	5	3.175	67	101	15	100	83	72	9	14	8.5	M8	4.8x2	2468	9586	105
OFV04010-4.8		10	6.35	82	124	18	174	102	94	11	17.5	11	M8	4.8x2	6316	18600	121
OFV05010-4.8	50	10	6.35	93	135	16	167	113	98	11	17.5	11	M8	4.8x2	7023	23537	144
OFV06310-4.8	63	10	6.35	108	154	22	177	130	110	14	20	13	M8	4.8x2	7860	30430	172
OFV08010-4.8	80	10	6.35	130	176	22	178	152	132	14	20	13	M8	4.8x2	8593	38344	201
DFV01510-2.7	15	10	3.175	34	58	10	107	45	34	5.5	9.5	5.5	M6	2.7x1	972	2020	30
DFV01604-3.8	16	4	2.381	34	57	11	89	45	34	5.5	9.5	5.5	M6	3.8x1	931	2285	42
DFV02004-4.8	20	4	2.381	40	60	10	94	50	40	4.5	8	4	M6	4.8x1	1247	3584	61
DFV02010-2.7		10	3.969	46	74	13	117	59	46	6.6	11	6.5	M6	2.7x1	1518	3398	40
DFV02506-4.8	25	6	3.969	53	76	11	116	64	58	5.5	9.5	5.5	M6	4.8x1	2711	7268	78
DFV02508-4.8		8	4.762	56	85	13	134	71	64	6.5	11	6.5	M6	4.8x1	3466	8776	82
DFV02510-2.7	10	6.35	68	102	15	130	84	82	9	14	8.5	M8	2.7x1	3040	6547	49	
DFV03204-4.8	32	4	2.381	54	81	12	94	67	64	6.6	11	6.5	M6	4.8x1	1517	5806	85
DFV03206-4.8		6	3.969	62	89	12	114	75	68	6.6	11	6.5	M8	4.8x1	3079	9575	95
DFV03208-4.8		8	4.762	66	100	15	139	82	76	9	14	8.5	M8	4.8x1	3962	11547	100
DFV03220-2.7		20	6.35	74	108	16	200	90	82	9	14	8.5	M8	2.7x1	3509	8644	61
DFV04020-2.7	40	20	6.35	82	124	18	200	102	90	11	17.5	11	M8	2.7x1	3935	10893	74
DFV05005-4.8	50	5	3.175	80	114	15	115	96	82	9	14	8.5	M8	4.8x1	2698	12053	122
DFV05020-2.7		20	9.525	105	152	28	221	128	110	14	20	13	M8	2.7x1	7336	19700	90
DFV06320-2.7	63	20	9.525	122	180	28	220	150	130	18	26	17.5	M8	2.7x1	8162	24741	107
DFV08020-4.8	80	20	9.525	143	204	28	340	172	148	18	26	18	M8	4.8x1	15103	57296	226
DFV08020-7.6		20	9.525	143	204	28	460	172	148	18	26	18	M8	3.8x2	22423	90719	351

Note : For double ball screw nut order, please contact LTROBOT in advance.

SFY Series Specifications

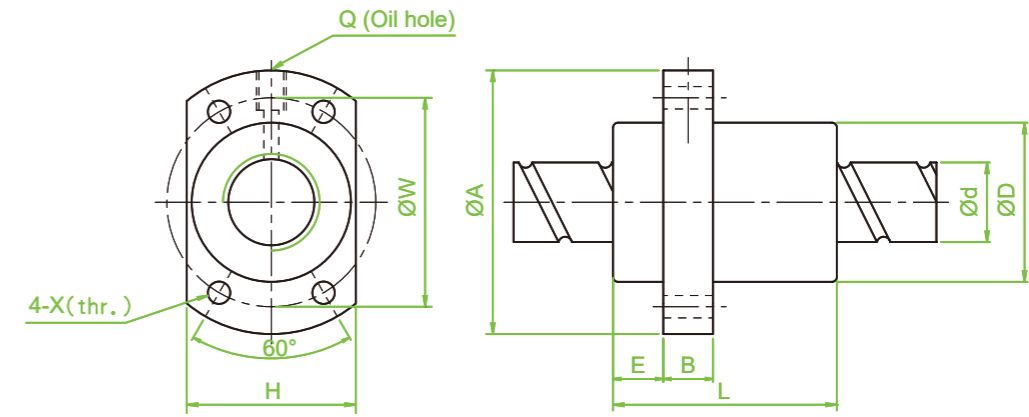

Unit : mm

Large Lead Model No.	d	l	Da	Dimension											Load Rating		K kgf/µm
				D	A	E	B	L	W	H	X	Q	n	Ca (kgf)	Coa (kgf)		
SFY01616-3.6	16	16	2.778	32	53	10.1	10	45	42	34	4.5	M6	1.8x2	1073	2551	31	
SFY01616-5.6		16	2.778	32	53	10.1	10	61	42	34	4.5	M6	2.8x2	1568	3968	47	
SFY02020-3.6	20	20	3.175	39	62	13	10	52	50	41	5.5	M6	1.8x2	1387	3515	37	
SFY02020-5.6		20	3.175	39	62	13	10	72	50	41	5.5	M6	2.8x2	2029	5468	56	
SFY02525-3.6	25	25	3.969	47	74	15	12	64	60	49	6.6	M6	1.8x2	2074	5494	45	
SFY02525-5.6		25	3.969	47	74	15	12	89	60	49	6.6	M6	2.8x2	3032	8546	69	
SFY03232-3.6	32	32	4.762	58	92	17	12	78	74	60	9	M6	1.8x2	3021	8690	58	
SFY03232-5.6		32	4.762	58	92	17	12	110	74	60	9	M6	2.8x2	4417	13517	88	
SFY04040-3.6	40	40	6.35	73	114	19.5	15	99	93	75	11	M6	1.8x2	4831	14062	70	
SFY04040-5.6		40	6.35	73	114	19.5	15	139	93	75	11	M6	2.8x2	7065	21874	106	
SFY05050-3.6	50	50	7.938	90	135	21.5	20	117	112	92	14	M6	1.8x2	7220	21974	86	
SFY05050-5.6		50	7.938	90	135	21.5	20	167	112	92	14	M6	2.8x2	10558	34182	131	
Twin Lead Model No.	d	l	Da	Dimension											Ca (kgf)	Coa (kgf)	K kgf/µm
SFY01632-1.6	16	32	2.778	32	53	10.1	10	42.5	42	34	4.5	M6	0.8x2	493	1116	11	
SFY01632-3.6		32	2.778	32	53	10.1	10	74.5	42	34	4.5	M6	1.8x2	989	2511	23	
SFY02040-1.6	20	40	3.175	39	62	13	10	48	50	41	5.5	M6	0.8x2	653	1597	15	
SFY02040-3.6		40	3.175	39	62	13	10	88	50	41	5.5	M6	1.8x2	1311	3592	30	
SFY02550-1.6	25	50	3.969	47	74	15	12	58	60	49	6.6	M6	0.8x2	976	2495	19	
SFY02550-3.6		50	3.969	47	74	15	12	108	60	49	6.6	M6	1.8x2	1960	5614	32	
SFY03264-1.6	32	64	4.762	58	92	17	12	71	74	60	9	M6	0.8x2	1374	3571	22	
SFY03264-3.6		64	4.762	58	92	17	12	135	74	60	9	M6	1.8x2	2759	8441	46	
SFY04080-1.6	40	80	6.35	73	114	19.5	15	90	93	75	11	M6	0.8x2	2273	6387	29	
SFY04080-3.6		80	6.35	73	114	19.5	15	170	93	75	11	M6	1.8x2	4566	14370	50	
SFY050100-1.6	50	100	7.938	90	135	21.5	20	111	112	92	14	M6	0.8x2	3398	9980	35	
SFY050100-3.6		100	7.938	90	135	21.5	20	211	112	92	14	M6	1.8x2	6824	22455	72	

3-8 Ground Ball Screw Series

DFS (DIN 69051 FORM B) Series Specifications

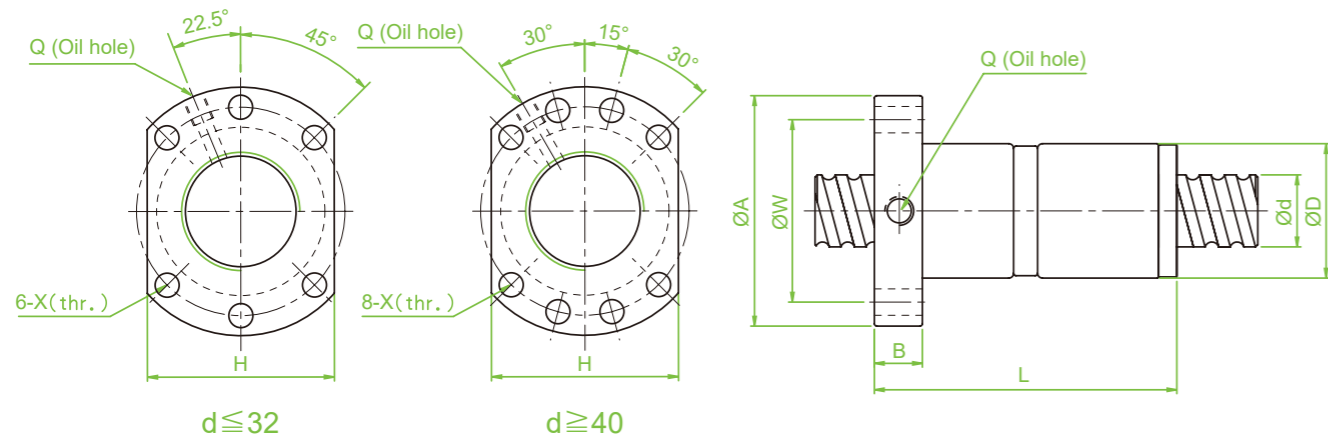

Unit : mm

Model No.	d	l	Da	Dimension									Load Rating		K kgf/ μ m
				D	A	B	L	W	H	X	Q	n	Ca (kgf)	Coa (kgf)	
DFS01605-3.8	15	5	2.778	28	48	10	73	38	40	5.5	M6	3.8x1	1112	2507	41
DFS01610-2.8		10	2.778	28	48	10	97	38	40	5.5	M6	2.8x1	839	1821	31
DFS02005-3.8	20	5	3.175	36	58	10	75	47	44	6.6	M6	3.8x1	1484	3681	50
DFS02010-3.8		10	3.175	36	58	10	120	47	44	6.6	M6	3.8x1	1516	3833	53
DFS02505-3.8	25	5	3.175	40	62	10	75	51	48	6.6	M6	3.8x1	1650	4658	59
DFS02510-3.8		10	3.175	40	62	12	122	51	48	6.6	M6	3.8x1	1638	4633	61
DFS03205-3.8	32	5	3.175	50	80	12	82	65	62	9	M6	3.8x1	1839	6026	71
DFS03210-3.8	31	10	3.969	50	80	13	122	65	62	9	M6	3.8x1	2460	7255	75
DFS03220-2.8		20	3.969	50	80	12	160	65	62	9	M6	2.8x1	1907	5482	58
DFS04005-3.8	40	5	3.175	63	93	15	85	78	70	9	M8	3.8x1	2018	7589	83
DFS04010-3.8	38	10	6.35	63	93	14	123	78	70	9	M8	3.8x1	5035	13943	91
DFS04020-2.8		20	6.35	63	93	14	162	78	70	9	M8	2.8x1	3959	10715	73
DFS05005-3.8	50	5	3.175	75	110	15	85	93	85	11	M8	3.8x1	2207	9542	96
DFS05010-3.8	48	10	6.35	75	110	18	138	93	85	11	M8	3.8x1	5638	17852	109
DFS05020-3.8		20	6.35	75	110	18	218	93	85	11	M8	3.8x1	5749	18485	116

Note : For double ball screw nut order, please contact LTROBOT in advance.

SCNI/SCI Series Specifications

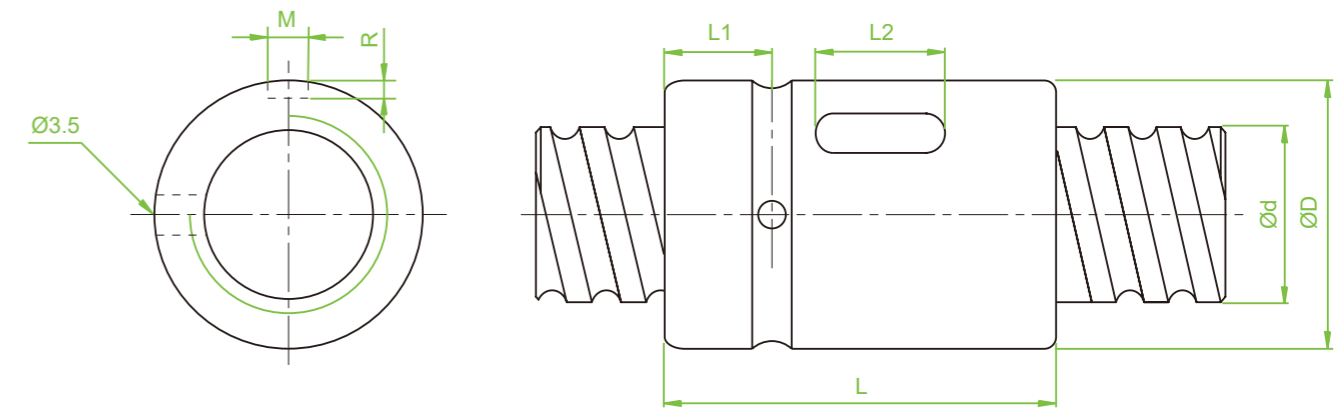

Unit : mm

Model No.	d	l	Da	Dimension							Load Rating		K kgf/ μ m
				D	L	L1	L2	M	R	n	Ca (kgf)	Coa (kgf)	
SCNI 01605-4	16	5	3.175	30	45	9	20	5	3	1x4	1380	3052	33
SCNI 02005-4	20	5	3.175	34	45	9	20	5	3	1x4	1551	3875	39
SCNI 02505-4	25	5	3.175	40	45	9	20	5	3	1x4	1724	4904	45
SCNI 02510-4		10	4.762	46	85	13	30	5	3	1x4	2954	7295	51
SCNI 03205-4	32	5	3.175	46	45	9	20	5	3	1x4	1922	6343	52
SCNI 03210-4		10	6.35	54	85	13	30	5	3	1x4	4805	12208	62
SCNI 04005-4	40	5	3.175	56	45	9	20	5	3	1x4	2110	7988	59
SCNI 04010-4		10	6.35	62	85	13	30	5	3	1x4	5399	15500	72
SCNI 05010-4	50	10	6.35	72	85	13	30	5	3	1x4	6004	19614	83
SCNI 06310-4	63	10	6.35	85	85	13	30	6	3.5	1x4	6719	25358	95
SCNI 08010-4	80	10	6.35	105	85	13	30	8	4.5	1x4	7346	31953	109
SCI 01604-4	16	4	2.381	30	40	9	15	3	1.5	1x4	973	2406	32
SCI 02004-4	20	4	2.381	34	40	9	15	3	1.5	1x4	1066	2987	37
SCI 02504-4	25	4	2.381	40	40	9	15	3	1.5	1x4	1180	3795	43
SCI 03204-4	32	4	2.381	46	40	9	15	3	1.5	1x4	1296	4838	49

3-8 Ground Ball Screw Series

SFK Series Specifications

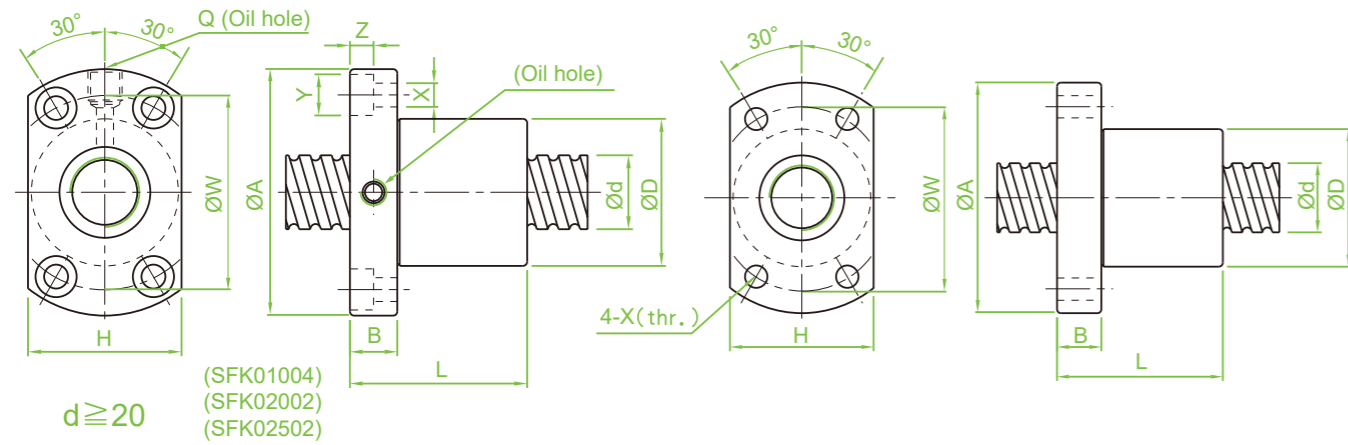

Unit : mm

Model No.	d	l	Da	Dimension											Ca (kgf)	Coa (kgf)	K kgf/ μ m
				D	A	B	L	W	H	X	Y	Z	Q	n			
SFK00401	4	1	0.8	10	20	3	12	15	14	2.9	—	—	—	1x2	64	97	5
SFK00601	6	1	0.8	12	24	3.5	15	18	16	3.4	—	—	—	1x3	111	224	9
SFK00801*	8	1	0.8	14	27	4	16	21	18	3.4	—	—	—	1x4	161	403	14
SFK00802*		2	1.2	14	27	4	16	21	18	3.4	—	—	—	1x3	222	458	13
SFK0082.5		2.5	1.2	16	29	4	26	23	20	3.4	—	—	—	1x3	221	457	13
SFK01002*	10	2	1.2	18	35	5	28	27	22	4.5	—	—	—	1x3	243	569	15
SFK01004		4	2	26	46	10	34	36	28	4.5	8	4.5	M6	1x3	468	905	17
SFK01202*	12	2	1.2	20	37	5	28	29	24	4.5	—	—	—	1x4	334	906	22
SFK01402*	14	2	1.2	21	40	6	23	31	26	5.5	—	—	—	1x4	354	1053	24
SFK01602*	16	2	1.2	25	43	10	40	35	29	5.5	—	—	M6	1x4	373	1200	26
SFK02002	20	2	1.2	50	80	15	55	65	68	6.5	10.5	6	M6	1x6	581	2284	48
SFK02502	25	2	1.2	50	80	13	43	65	68	6.5	10.5	6	M6	1x5	540	2381	46

※ ☆ Left helix available

Unit : mm

Model No.	d	l	Da	Dimension											Ca (kgf)	Coa (kgf)	K kgf/ μ m
				D	A	B	L	W	H	X	Y	Z	Q	n			
XSUR01204T3D-02	12	4	2.5	24	40	6	28	32	25	3.5	—	—	—	1x3	704	1413	—
XSUR01205T3D-00		5	2.5	22	37	8	39	29	24	4.5	—	—	—	1x3	702	1409	17

BSH Series Specifications

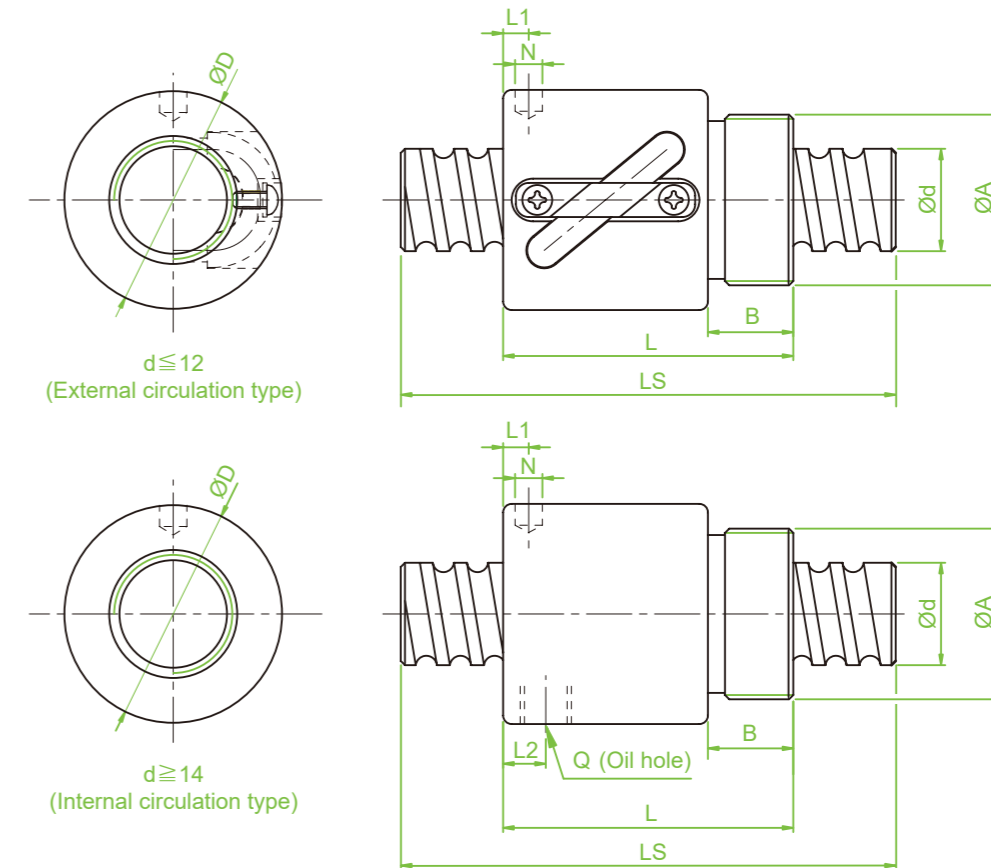

Unit : mm

Model No.	d	l	Da	Dimension											Ca (kgf)	Coa (kgf)	K kgf/ μ m
				D	A	B	L	L1	N	L2	Q	n					
BSHR0082.5-2.5	8	2.5	1.2	17.5	M15x1P	7.5	23.5	10	3	—	—	—	2.5x1	189	381	11	
BSHR01002-3.5	10	2	1.2	19.5	M17x1P	7.5	22	3	3.2	—	—	—	3.5x1	277	664	17	
BSHR01004-2.5		4	2	25	M20x1P	10	34	3	3	—	—	—	2.5x1	400	754	14	
BSHR01204-3.5	12	4	2.5	25.5	M20x1P	10	34	13	3	—	—	—	3.5x1	804	1649	23	
BSHR01205-3.5		5	2.5	25.5	M20x1P	10	39	16.25	3	—	—	—	3.5x1	801	1644	24	
BSHR01404-3	14	4	2.5	32.1	M25x1.5P	10	35	11	3	—	—	—	1x3	748	1609	26	
BSHR01604-3	16	4	2.381	29	M22x1.5P	8	32	4	3.2	—	—	—	1x3	759	1804	24	
BSHR01605-3		5	3.175	32.5	M26x1.5P	12	42	19.25	3	—	—	—	1x3	1077	2289	25	
BSHR01610-2		10	3.175	32	M26x1.5P	12	50	3	4	3	M4	1x2	779	1601	14		
BSHR02005-3	20	5	3.175	38	M35x1.5P	15	45	20.3	3	—	—	—	1x3	1211	2906	30	
BSHR02505-4	25	5	3.175	43	M40x1.5P	19	69	32.11	3	8	M6	1x4	1724	4904	37		
BSHR02510-4		10	4.762	43	M40x1.5P	19	84	8	6	8	M6	1x4	2954	7295	41		

※ Standard ball nut from $\varnothing 8$ - $\varnothing 16$ is assembled without wiper.

3-9 Rolled Ball Screw

3-9-1 Rolled Screws

Rolled screws are made through thread roller. Generally rolled screw has a smoother operation while lowering friction and backlash. Therefore, it gradually replaced the traditional ACME screws and trapezoidal screws. Moreover, rolled screws can eliminate axial play by preloading nut with a cost effective pricing compare to ground screw.

3-9-2 The Features of LTROBOT Rolled Ball Screw

(1) Lead Accuracy Up to Grade C5

C7 and C10 Screws have been Standardized. C5 on request.

(2) Precision Ground Ball Nut

High Precision Ball Nut are interchangeable between ground and rolled screws.

(3) Available to ship separately

Ball screw and ball nuts can be shipped separated ensure shortest delivery time. The ball nuts are standardized with P0 preloaded, preload value can be adjusted through reballing.

3-9-3 Nominal Model Code of Rolled Ball Screws

Nominal Model Code of Shaft

SC R 025 05 F C7 - 1000 + N3

① ② ③ ④ ⑤ ⑥ ⑦ ⑧

① Type of Screw Shaft SC : standard SS : For H, NH type nut	④ Lead Unit : mm	⑦ Overall Length of Shaft Unit : mm
② Threading Direction R : Right L : Left	⑤ Product Code F : Rolled	⑧ Shaft Surface Treatment □ : Standard B1 : Black Oxidation N1 : Hard Chrome Plating P : Phosphating N3 : Nickel Plating N4 : Raydent N5 : Chrome Plating
③ Nominal Diameter Unit : mm	⑥ Accuracy Grade C5, C7, C10	

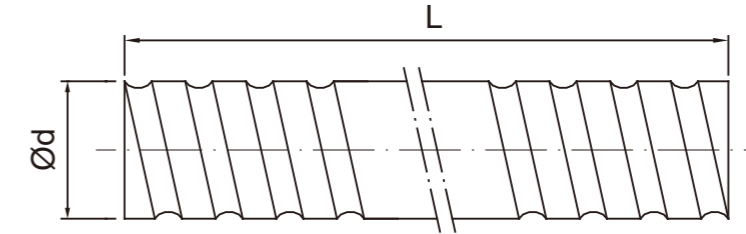

Fig 3.9.1 Screw Shaft Nominal Diameter

Table 3.9.1 Rolled Ball Screw Specifications Ø6~32

Unit : mm

Model No.	Accuracy Grade	Threading Direction	Number of Grooves	Standard Code of Shaft	Type of Nut	Overall Length of Shaft		
							d	l
6	1	0.8	C10, C7	R	1	SCR00601	K	1000
8	1	0.8	C10, C7, C5	R	1	SCR00801	K	1000
	2	1.2	C10, C7, C5	R	1	SCR00802	K	
10	2.5	1.2	C10, C7, C5	R	1	SCR0082.5	K, BSH	3000
	2	1.2	C10, C7, C5	R	1	SCR01002	K, BSH	
12	4	2	C10, C7, C5	R	1	SCR01004	K, BSH	3000
	2	1.2	C10, C7, C5	R	1	SCR01202	K	
	4	2.5	C10, C7, C5	R	1	SCR01204	U, BSH	
	5	2.5	C10, C7, C5	R	1	SCR01205-A	V, U, BSH, H, A	
14	10	2.5	C10, C7, C5	R	2	SCR01210-B	V	3000
	20	2.5	C10, C7	R	4	SCR01220	Y	
	2	1.2	C10, C7, C5	R	1	SCR01402	K	
16	4	2.5	C10, C7	R	1	SCR01404	BSH	3000
	4	2.381	C10, C7, C5	R	1	SCR01604(N)	V, I, U, BSH	
20	5	3.175	C10, C7, C5	R/L	1	SCR01605	V, NI, NU, BSH	3000
	10	3.175	C10, C7, C5	R	2	SCR01610	V, NI, NU, BSH	
	16	2.778	C10, C7, C5	R	4	SCR01616	Y	
	32	2.778	C10, C7	R	8	SCR01632	Y	
25	4	2.381	C10, C7, C5	R	1	SCR02004(N)	V, I, U	3000
	5	3.175	C10, C7, C5	R/L	1	SCR02005	V, NI, NU, BSH, H, A	
	20	3.175	C10, C7, C5	R	4	SCR02020	V, Y, H, A	
32	40	3.175	C10, C7	R	8	SCR02040	Y	6000
	4	2.381	C10, C7	R	1	SCR02504(N)	I, U	
	5	3.175	C10, C7, C5	R/L	1	SCR02505	V, NI, NU, BSH, H, A	
	10	4.762	C10, C7, C5	R	1	SCR02510-A	NI, NU, BSH	
32	10	6.35	C10, C7, C5	R	1	SCR02510-B	V	6000
	25	3.969	C10, C7, C5	R	4	SCR02525	Y	
	50	3.969	C10, C7	R	8	SCR02550	Y	
	4	2.381	C10, C7, C5	R	1	SCR03204(N)	V, I, U	
32	5	3.175	C10, C7, C5	R/L	1	SCR03205	V, NI, NU, M, H, A	6000
	10	6.35	C10, C7, C5	R/L	1	SCR03210	V, NI, NU	
	32	4.762	C10, C7	R	4	SCR03232	Y	
	64	4.762	C10, C7	R	8	SCR03264	Y	

Table3.9.2 Standard Specifications Ø40~80

Unit : mm

Model No.			Accuracy Grade	Threading Direction	Number of Grooves	Standard Code of Shaft	Type of Nut	Overall Length of Shaft
d	l	Da		R : Right L : Left				
40	5	3.175	C10, C7, C5	R/L	1	SCR04005	V, NI, NU, H, A	6000
	10	6.35	C10, C7	R/L	1	SCR04010	V, NI, NU	
	20	6.35	C10, C7	R	2	SCR04020	V	
	40	6.35	C10, C7	R	4	SCR04040	Y	
	80	6.35	C10, C7	R	8	SCR04080	Y	
50	5	3.175	C10, C7, C5	R	1	SCR05005	V, H, A	6000
	10	6.35	C10, C7, C5	R/L	1	SCR05010	V, NI, NU	
	20	9.525	C10, C7	R	1	SCR05020	V	
	50	7.938	C10, C7	R	4	SCR05050	Y	
	100	7.938	C10, C7	R	8	SCR050100	Y	
63	10	6.35	C10, C7, C5	R	1	SCR06310	V, NI, NU	7000
	20	9.525	C10, C7	R	1	SCR06320	V, NU	
80	10	6.35	C10, C7, C5	R	1	SCR08010	V, NI, NU	7000
	20	9.525	C10, C7	R	1	SCR08020	V, U	

Table3.9.3 H, A-Type Specifications Ø16~50

Unit : mm

Model No.			Accuracy Grade	Threading Direction	Number of Grooves	Type-H Code of Shaft	Type of Nut	Overall Length of Shaft
d	l	Da		R : Right L : Left				
12	10	2.5	C10, C7, C5	R	2	SSR01210	H, A	3000
16	5	2.778	C10, C7, C5	R	1	SSR01605	H, A	3000
	10	2.778	C10, C7, C5	R	2	SSR01610	H, A	
	16	2.778	C10, C7, C5	R	4	SSR01616	H, A	
	20	2.778	C10, C7, C5	R	4	SSR01620	H, A	
20	10	3.175	C10, C7, C5	R	2	SSR02010	H, A	3000
25	10	3.175	C10, C7, C5	R	2	SSR02510	H, A	6000
	25	3.175	C10, C7	R	4	SSR02525	H, A	
32	10	3.969	C10, C7, C5	R	1	SSR03210	H, A	6000
	20	3.969	C10, C7	R	2	SSR03220	H, A	
	32	3.969	C10, C7	R	4	SSR03232	H, A	
40	10	6.35	C10, C7	R	1	SSR04010	H, A	6000
	20	6.35	C10, C7, C5	R	2	SSR04020	H, A	
	40	6.35	C10, C7	R	4	SSR04040	H, A	
50	10	6.35	C10, C7	R	1	SSR05010	H, A	6000
	20	6.35	C10, C7	R	2	SSR05020	H, A	
	50	6.35	C10, C7	R	4	SSR05050	H, A	

Nominal Model Code of Nut

G SFU R 025 05 T4 D + N3

① ② ③ ④ ⑤ ⑥ ⑦ ⑧

①

Product Code

②

Nominal Model

S	S : Single nut
	D : Double nut
F	F : With flange
	C : Without flange
U	NI : NI type nut
	NU : NU type nut
	H : H type nut
	A : A type nut
	NH : NH nut (A solution for slide table)
	Y : Y type nut
	V : V type nut
U : DIN nut	
M : M type nut	
K : K type nut	

③

Threading Direction

R : Right
L : Left

⑥

Number of Turns (Turn-Row)

Turn : T : 1
A : 1.5 (or 1.7/1.8)
B : 2.5/2.8
C : 3.5
D : 4.8
ex : (2.5 × 2 = B2)

④

Nominal Diameter

Unit : mm

⑤

Lead

Unit : mm

⑦

Flange Type

N : Not cutting
S : Single cutting
D : Double cutting

⑧

Nut Surface Treatment

S : Standard
B1 : Black Oxidation
N1 : Hard Chrome Plating
P : Phosphating
N3 : Nickel Plating
N4 : Raydent
N5 : Chrome Plating

3-9-4 Preload of Rolled Ball Screw

The standard preloading for Rolled Ball Screw is P0. If P1 preloading is required, please contact LTROBOT

Table3.9.4 Rolled screw accuracy

Unit : μm

Accuracy Grade	C5 (DIN)	C7	C10
e300	23	50	210

3-10 Rolled Ball Screw Series

3-10-1 LTROBOT Nut of Rolled Ball Screw Type

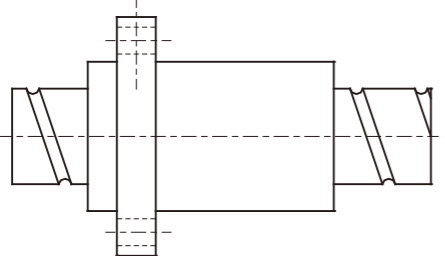
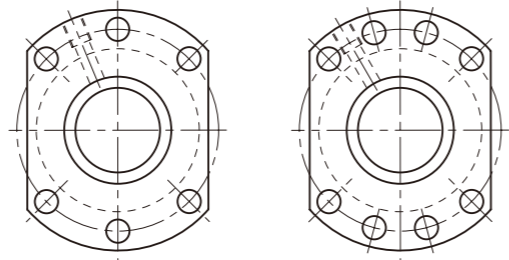
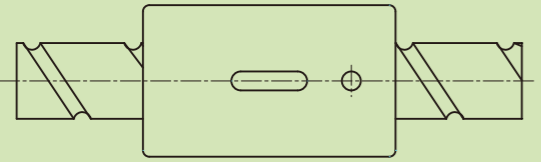
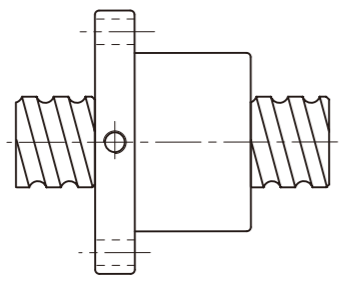
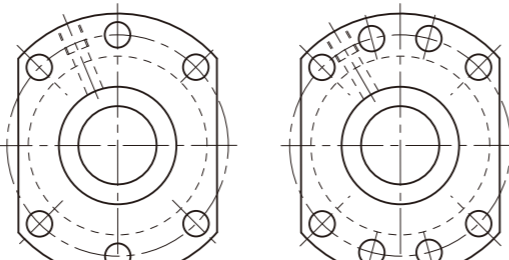
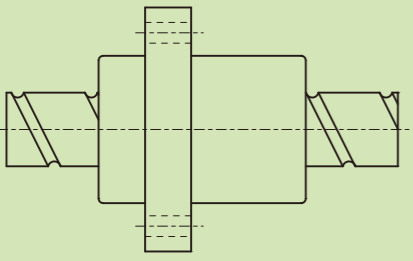
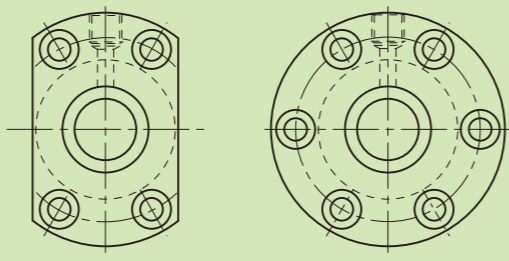
	Nut Type	Flange Type
NH/H/A (A solution for slide table/High Speed/Strong dust-proof type)	<p>SFNH/SFH/SFA(DIN)</p>  <p>P78,79</p>	 <p>$d \leq 32$ $d \geq 40$</p>
CNH (A solution for slide table)	<p>SCNH</p>  <p>P80</p>	No-Flange
NU/U (Strong dust-proof type)	<p>SFNU/ SFU(DIN)</p>  <p>P81</p>	 <p>$d \leq 32$ $d \geq 40$</p>
NI/I (Strong dust-proof type)	<p>SFNI/SFI</p>  <p>P82</p>	

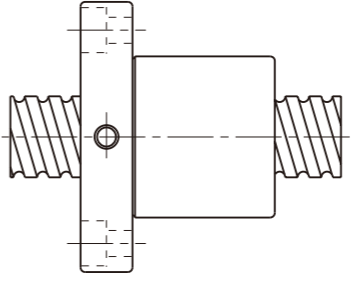
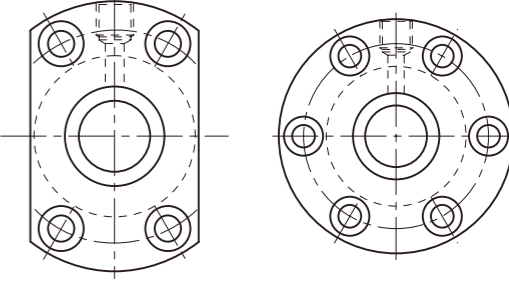
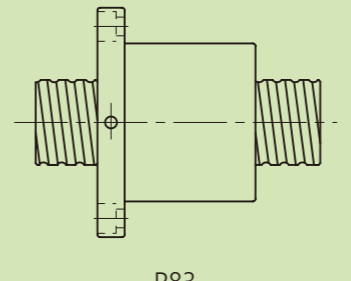
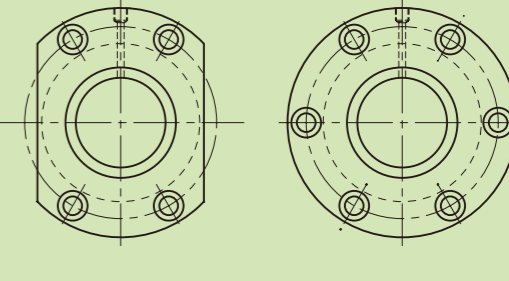
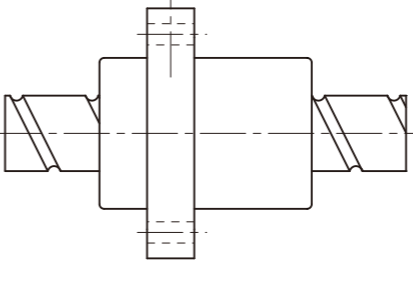
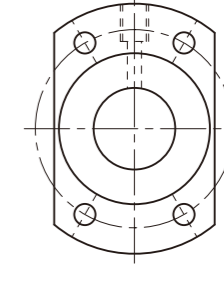
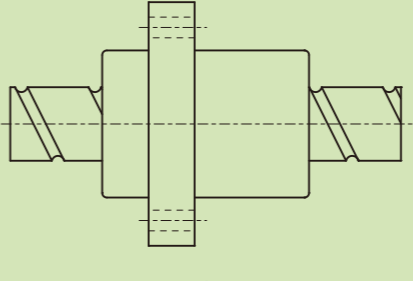
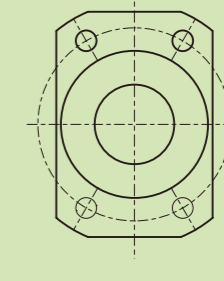
	Nut Type	Flange Type
Σ (Design for Milling)	<p>SFM</p>  <p>P82</p>	
∇ (High Load External Circulation type)	<p>SFV</p>  <p>P83</p>	
∇ (High DM-N Rating)	<p>SFY</p>  <p>P84</p>	
XSY (Miniature type)	<p>XSY</p>  <p>P84</p>	

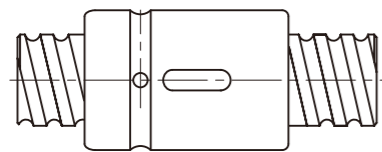
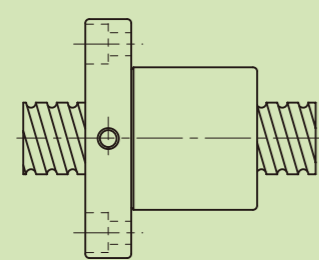
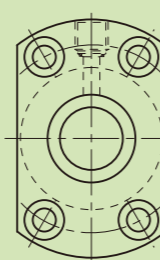
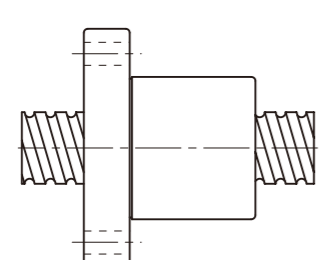
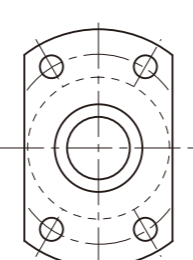
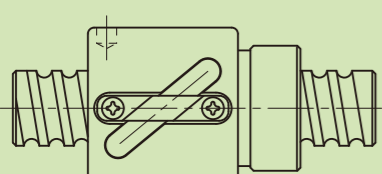
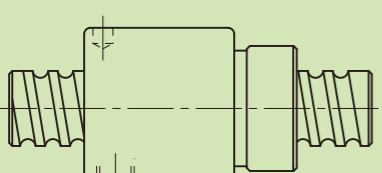
	Nut Type	Flange Type
CNI/I (Standard)	<p>SCNI/SCI</p>  <p>P85</p>	No-Flange
M (Miniature type)	<p>SFK</p>  <p>P86</p>	 <p>(SFK 01004) (SFK 02002) (SFK 02502)</p>
	<p>SFK</p>  <p>P86</p>	
BSH	<p>BSH</p>  <p>d ≤ 12</p>  <p>d ≥ 14</p> <p>P87</p>	No-Flange

3-10 Rolled Ball Screw Series

SFNH/SFH (DIN 69051 FORM B) Series Specifications

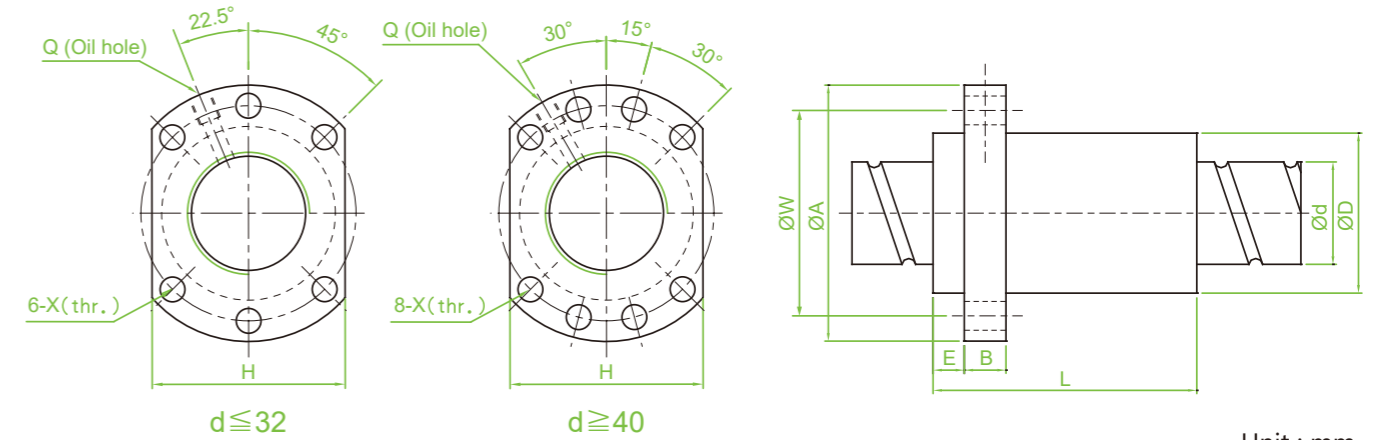

Unit : mm

Model No.	d	l	Da	Dimension										Load Rating		K kgf/μm	
				D	A	E	B	L	W	H	X	Q	n	Ca (kgf)	Coa (kgf)		
SFH01205-2.8 *	12	5	2.5	24	40	5	10	30	32	30	4.5		2.8x1	661	1316	19	
SFH01210-2.8 *		10	2.5	24	40	5	10	45	32	30	4.5		2.8x1	642	1287	19	
SFH01605-3.8 *	15	5	2.778	28	48	5	10	37	38	40	5.5	M6	3.8x1	1112	2507	30	
SFH01610-2.8 *		10	2.778	28	48	5	10	45	38	40	5.5	M6	2.8x1	839	1821	23	
SFH01616-1.8 *		16	2.778	28	48	5	10	45	38	40	5.5	M6	1.8x1	552	1137	14	
SFH01616-2.8 *		16	2.778	28	48	5	10	61	38	40	5.5	M6	2.8x1	808	1769	22	
SFH01620-1.8 *	20	20	2.778	28	48	7	10	58	38	40	5.5	M6	1.8x1	554	1170	14	
SFH02005-3.8 *		5	3.175	36	58	7	10	37	47	44	6.6	M6	3.8x1	1484	3681	37	
SFH02010-3.8 *		10	3.175	36	58	7	10	55	47	44	6.6	M6	3.8x1	1516	3833	40	
SFH02020-1.8 *		20	3.175	36	58	7	10	54	47	44	6.6	M6	1.8x1	764	1758	19	
SFH02020-2.8 *	25	20	3.175	36	58	7	10	74	47	44	6.6	M6	2.8x1	1118	2734	29	
SFH02505-3.8 *		5	3.175	40	62	7	10	37	51	48	6.6	M6	3.8x1	1650	4658	43	
SFH02510-3.8 *		10	3.175	40	62	7	12	55	51	48	6.6	M6	3.8x1	1638	4633	45	
SFH02525-1.8 *		25	3.175	40	62	7	12	64	51	48	6.6	M6	1.8x1	843	2199	22	
SFH02525-2.8 *	32	25	3.175	40	62	7	12	89	51	48	6.6	M6	2.8x1	1232	3421	34	
SFH03205-3.8		5	3.175	50	80	9	12	37	65	62	9	M6	3.8x1	1839	6026	51	
SFH03210-3.8		10	3.969	50	80	9	12	57	65	62	9	M6	3.8x1	2460	7255	55	
SFH03220-2.8		31	20	3.969	50	80	9	12	76	65	62	9	M6	2.8x1	1907	5482	43
SFH03232-1.8	32		3.969	50	80	9	12	80	65	62	9	M6	1.8x1	1257	3426	27	
SFH03232-2.8	40	32	3.969	50	80	9	12	112	65	62	9	M6	2.8x1	1838	5329	42	
SFH04005-3.8		5	3.175	63	93	9	15	42	78	70	9	M8	3.8x1	2018	7589	60	
SFH04010-3.8		38	10	6.35	63	93	9	14	60	78	70	9	M8	3.8x1	5035	13943	67
SFH04020-2.8			20	6.35	63	93	9	14	80	78	70	9	M8	2.8x1	3959	10715	54
SFH04040-1.8	48	40	6.35	63	93	9	14	98	78	70	9	M8	1.8x1	2585	6648	34	
SFH04040-2.8		40	6.35	63	93	9	14	138	78	70	9	M8	2.8x1	3780	10341	52	
SFH05005-3.8	50	5	3.175	75	110	10.5	15	42	93	85	11	M8	3.8x1	2207	9542	68	
SFH05010-3.8		10	6.35	75	110	10.5	18	60	93	85	11	M8	3.8x1	5638	17852	79	
SFH05020-3.8		48	20	6.35	75	110	10.5	18	100	93	85	11	M8	3.8x1	5749	18485	87
SFH05050-1.8			50	6.35	75	110	10.5	18	120	93	85	11	M8	1.8x1	2946	8749	42
SFH05050-2.8	48	50	6.35	75	110	10.5	18	170	93	85	11	M8	2.8x1	4308	13610	65	

※ ★ Actuator type available.
※ Please contact LTROBOT if the marked types (●) are required.

3-10 Rolled Ball Screw Series

SFA Series Specifications

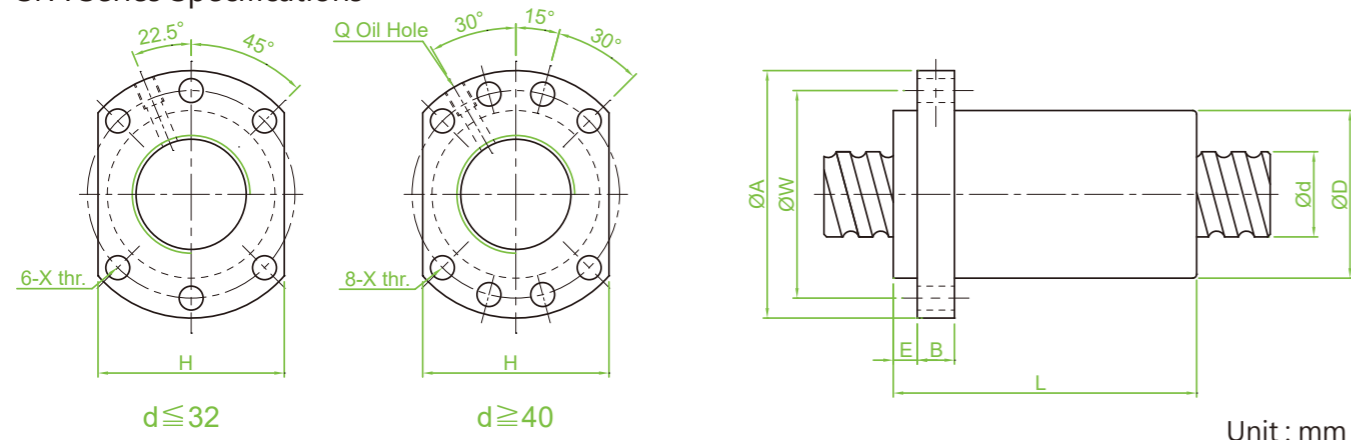

Unit : mm

Model No.	d	l	Da	Dimension										Load Rating		K kgf/ μ m
				D	A	E	B	L	W	H	X	Q	n	Ca (kgf)	Coa (kgf)	
SFA1205-2.8*	12	5	2.5	24	40	5	10	30	32	30	4.5		2.8x1	661	1316	19
SFA1210-2.8*		10	2.5	24	40	5	10	42	32	30	4.5		2.8x1	642	1287	19
SFA1605-3.8*	15	5	2.778	28	48	5	10	31	38	40	5.5	M6	3.8x1	1112	2507	30
SFA1610-2.8*		10	2.778	28	48	5	10	42	38	40	5.5	M6	2.8x1	839	1821	23
SFA1616-1.8*		16	2.778	28	48	5	10	43	38	40	5.5	M6	1.8x1	552	1137	14
SFA1616-2.8*		16	2.778	28	48	5	10	59	38	40	5.5	M6	2.8x1	808	1769	22
SFA1620-1.8*		20	2.778	28	48	5	10	50	38	40	5.5	M6	1.8x1	554	1170	14
SFA1630-1.8*		30	2.778	28	48	7	10	70	38	40	5.5	M6	1.8x1	534	1195	14
SFA2005-3.8*	20	5	3.175	36	58	7	10	33	47	44	6.6	M6	3.8x1	1484	3681	37
SFA2010-3.8*		10	3.175	36	58	7	10	52	47	44	6.6	M6	3.8x1	1516	3833	40
SFA2020-1.8*		20	3.175	36	58	7	10	52	47	44	6.6	M6	1.8x1	764	1758	19
SFA2020-2.8*		20	3.175	36	58	7	10	72	47	44	6.6	M6	2.8x1	1118	2734	29
SFA2505-3.8*	25	5	3.175	40	62	7	10	33	51	48	6.6	M6	3.8x1	1650	4658	43
SFA2510-3.8*		10	3.175	40	62	7	12	52	51	48	6.6	M6	3.8x1	1638	4633	45
SFA2525-1.8*		25	3.175	40	62	7	12	60	51	48	6.6	M6	1.8x1	843	2199	22
SFA2525-2.8*		25	3.175	40	62	7	12	85	51	48	6.6	M6	2.8x1	1232	3421	34
SFA3205-3.8	32	5	3.175	50	80	9	12	35	65	62	9	M6	3.8x1	1839	6026	51
SFA3210-3.8	31	10	3.969	50	80	9	12	53	65	62	9	M6	3.8x1	2460	7255	55
SFA3220-2.8		20	3.969	50	80	9	12	72	65	62	9	M6	2.8x1	1907	5482	43
SFA3232-1.8		32	3.969	50	80	9	12	78	65	62	9	M6	1.8x1	1257	3426	27
SFA3232-2.8		32	3.969	50	80	9	12	110	65	62	9	M6	2.8x1	1838	5329	42
SFA4005-3.8	40	5	3.175	63	93	9	14	39	78	70	9	M8	3.8x1	2018	7589	60
SFA4010-3.8	38	10	6.35	63	93	9	14	57	78	70	9	M8	3.8x1	5035	13943	67
SFA4020-2.8		20	6.35	63	93	9	14	78	78	70	9	M8	2.8x1	3959	10715	54
SFA4040-1.8		40	6.35	63	93	9	14	96	78	70	9	M8	1.8x1	2585	6648	34
SFA4040-2.8		40	6.35	63	93	9	14	136	78	70	9	M8	2.8x1	3780	10341	52
SFA5005-3.8*	50	5	3.175	75	110	10.5	15	42	93	85	11	M8	3.8x1	2207	9542	68
SFA5010-3.8*	48	10	6.35	75	110	10.5	18	57	93	85	11	M8	3.8x1	5638	17852	79
SFA5020-3.8*		20	6.35	75	110	10.5	18	98	93	85	11	M8	3.8x1	5749	18485	87
SFA5050-1.8*		50	6.35	75	110	10.5	18	117	93	85	11	M8	1.8x1	2946	8749	42
SFA5050-2.8*		50	6.35	75	110	10.5	18	167	93	85	11	M8	2.8x1	4308	13610	65

※ ★ Actuator type available.
 ※ Please contact **LTROBOT** if the marked types (●) are required.

SCNH Series Specifications

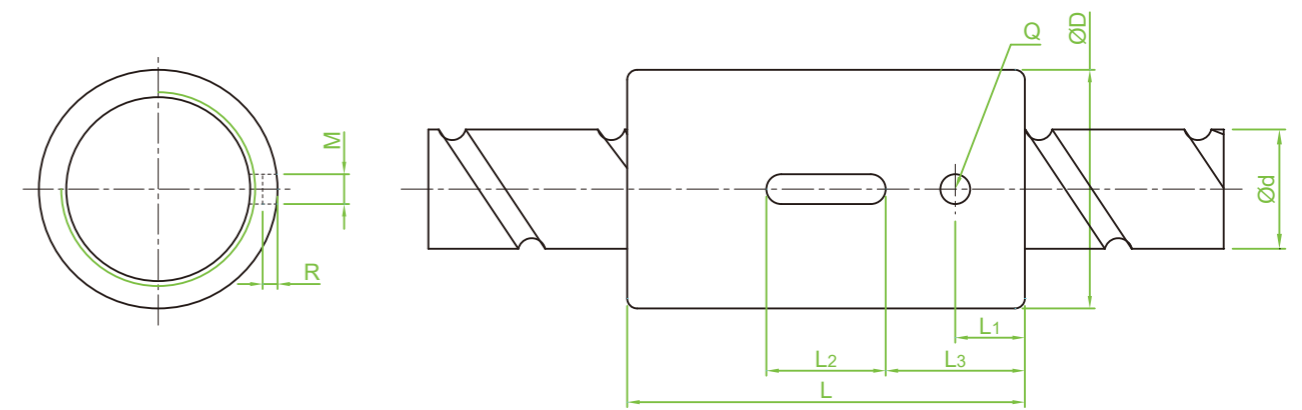

Unit : mm

Model No.	d	l	Da	Dimension										Load Rating		K kgf/ μ m
				D	L	L1	L2	L3	M	R	Q	n	Ca (kgf)	Coa (kgf)		
SCNH01205-4.8	12	5	2.5	24	40	7	12	14	3	1.5	3	4.8x1	1051	2255	34	
SCNH01210-2.8		10	2.5	24	45	8	15	15	3	1.5	3	2.8x1	642	1287	19	
XCNH01210-1.8		10	2.5	24	40	10.5	12	14	3	1.5	3	1.8x1	439	827	33	
SCNH01605-5.8	15	5	2.778	28	45	7	20	12.5	5	3	3	5.8x1	1599	3827	49	
SCNH01610-2.8		10	2.778	28	45	7	20	12.5	5	3	3	2.8x1	839	1821	23	
SCNH01616-1.8		16	2.778	28	45	7	20	12.5	5	3	3	1.8x1	552	1137	18	
SCNH01620-1.8		20	2.778	28	58	10	20	19	5	3	3	1.8x1	554	1170	14	
SCNH02005-5.8	20	5	3.175	36	47	8	20	13.5	5	3	3	5.8x1	2134	5619	60	
SCNH02010-3.8		10	3.175	36	55	8	20	17.5	5	3	3	3.8x1	1516	3833	40	
SCNH02020-1.8		20	3.175	36	55	8	20	17.5	5	3	3	1.8x1	764	1758	19	

3-10 Rolled Ball Screw Series

SFNU/SFU (DIN 69051 FORM B) Series Specifications

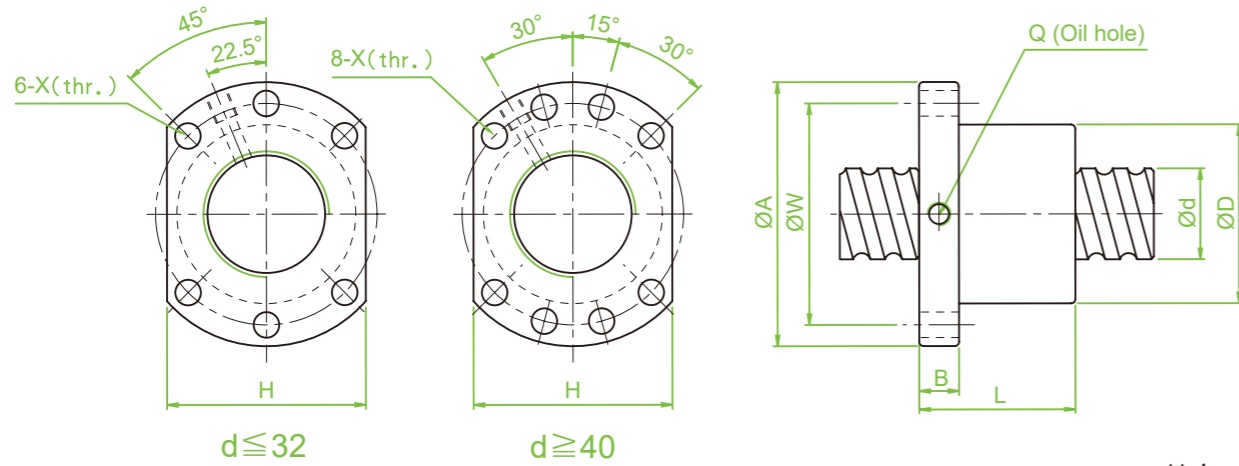

Unit : mm

Model No.	d	l	Da	Dimension									Load Rating		K kgf/ μ m
				D	A	B	L	W	H	X	Q	n	Ca (kgf)	Coa (kgf)	
SFNU01605-4*	16	5	3.175	28	48	10	45	38	40	5.5	M6	1x4	1380	3052	32
SFNU01610-3		10	3.175	28	48	10	57	38	40	5.5	M6	1x3	1103	2401	26
SFNU02005-4*	20	5	3.175	36	58	10	51	47	44	6.6	M6	1x4	1551	3875	39
SFNU02505-4*	25	5	3.175	40	62	10	51	51	48	6.6	M6	1x4	1724	4904	45
SFNU02510-4		10	4.762	40	62	12	80	51	48	6.6	M6	1x4	2954	7295	50
SFNU03205-4*	32	5	3.175	50	80	12	52	65	62	9	M6	1x4	1922	6343	54
SFNU03210-4*		10	6.35	50	80	12	85	65	62	9	M6	1x4	4805	12208	61
SFNU04005-4*	40	5	3.175	63	93	14	55	78	70	9	M8	1x4	2110	7988	63
SFNU04010-4*		10	6.35	63	93	14	88	78	70	9	M8	1x4	5399	15500	73
SFNU05010-4*	50	10	6.35	75	110	16	88	93	85	11	M8	1x4	6004	19614	85
SFNU06310-4*	63	10	6.35	90	125	18	93	108	95	11	M8	1x4	6719	25358	99
SFNU08010-4*	80	10	6.35	105	145	20	93	125	110	13.5	M8	1x4	7346	31953	109
SFU01204-4	12	4	2.5	24	40	10	40	32	30	4.5		1x4	902	1884	26
SFU01604-4	16	4	2.381	28	48	10	40	38	40	5.5	M6	1x4	973	2406	32
SFU02004-4	20	4	2.381	36	58	10	42	47	44	6.6	M6	1x4	1066	2987	38
SFU02504-4	25	4	2.381	40	62	10	42	51	48	6.6	M6	1x4	1180	3795	43
SFU02506-4		6	3.969	40	62	10	54	51	48	6.6	M6	1x4	2318	6057	47
SFU02508-4		8	4.762	40	62	10	63	51	48	6.6	M6	1x4	2963	7313	49
SFU03204-4	32	4	2.381	50	80	12	44	65	62	9	M6	1x4	1296	4838	51
SFU03206-4		6	3.969	50	80	12	57	65	62	9	M6	1x4	2632	7979	57
SFU03208-4		8	4.762	50	80	12	65	65	62	9	M6	1x4	3387	9622	60
SFU04006-4	40	6	3.969	63	93	14	60	78	70	9	M6	1x4	2873	9913	66
SFU04008-4		8	4.762	63	93	14	67	78	70	9	M6	1x4	3712	11947	70
SFU05020-4*	50	20	7.144	75	110	16	138	93	85	11	M8	1x4	7142	22588	94
SFU06320-4*	63	20	9.525	95	135	20	149	115	100	13.5	M8	1x4	11444	36653	112
SFU08020-4*	80	20	9.525	125	165	25	154	145	130	13.5	M8	1x4	12911	47747	138
SFU10020-4*	100	20	9.525	150	202	30	180	170	155	17.5	M8	1x4	14303	60698	162

※ ☆ Left helix available ※ Please contact LTROBOT if the marked types (●) are required.

SFNI/SFI Series Specifications

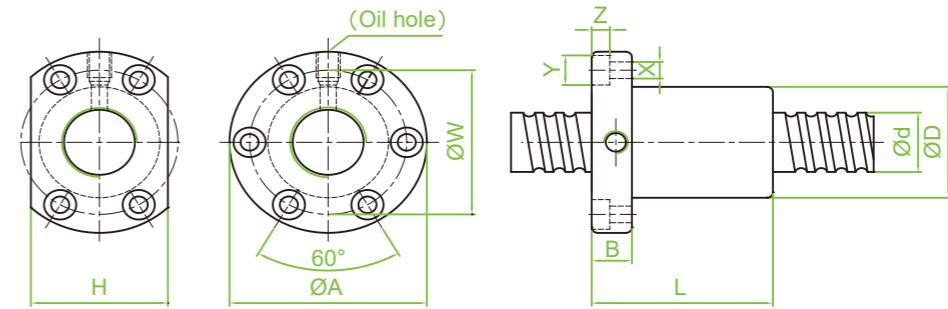

Unit : mm

Model No.	d	l	Da	Dimension										Load Rating		K kgf/ μ m	
				D	A	B	L	W	H	X	Y	Z	Q	n	Ca (kgf)		Coa (kgf)
SFNI01605-4*	16	5	3.175	30	49	10	45	39	34	4.5	8	4.5	M6	1x4	1380	3052	33
SFNI01610-3		10	3.175	34	58	10	57	45	34	5.5	9.5	5.5	M6	1x3	1103	2401	27
SFNI02005-4*	20	5	3.175	34	57	11	51	45	40	5.5	9.5	5.5	M6	1x4	1551	3875	39
SFNI02505-4*	25	5	3.175	40	63	11	51	51	46	5.5	9.5	5.5	M8	1x4	1724	4904	45
SFNI02510-4		10	4.762	46	72	12	80	58	52	6.5	11	6.5	M6	1x4	2954	7295	51
SFNI03205-4*	32	5	3.175	46	72	12	52	58	52	6.5	11	6.5	M8	1x4	1922	6343	52
SFNI03210-4*		10	6.35	54	88	15	85	70	62	9	14	8.5	M8	1x4	4805	12208	62
SFNI04005-4*	40	5	3.175	56	90	15	55	72	64	9	14	8.5	M8	1x4	2110	7988	59
SFNI04010-4*		10	6.35	62	104	18	88	82	70	11	17.5	11	M8	1x4	5399	15500	72
SFNI05010-4*	50	10	6.35	72	114	18	88	92	82	11	17.5	11	M8	1x4	6004	19614	83
SFNI06310-4*	63	10	6.35	85	131	22	93	107	95	14	20	13	M8	1x4	6719	25358	95
SFNI08010-4*	80	10	6.35	105	150	22	93	127	115	14	20	13	M8	1x4	7346	31953	109
SFI01604-4	16	4	2.381	30	49	10	45	39	34	4.5	8	4.5	M6	1x4	973	2406	32
SFI02004-4	20	4	2.381	34	57	11	46	45	40	5.5	9.5	5.5	M6	1x4	1066	2987	37
SFI0205T-4		5.08	3.175	34	57	11	51	45	40	5.5	9.5	5.5	M6	1x4	1550	3875	39
SFI02504-4	25	4	2.381	40	63	11	46	51	46	5.5	9.5	5.5	M6	1x4	1180	3795	43
SFI0255T-4		5.08	3.175	40	63	11	51	51	46	5.5	9.5	5.5	M8	1x4	1724	4903	45
SFI03204-4	32	4	2.381	46	72	12	47	58	52	6.5	11	6.5	M6	1x4	1296	4838	49

※ Please contact LTROBOT if the marked types (●) are required.

SFM Series Specifications (Design for Milling)

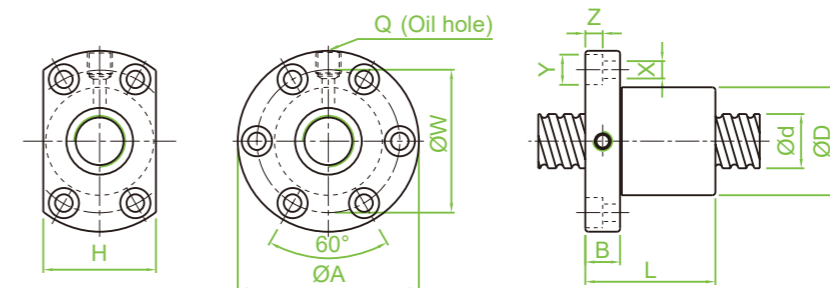

Unit : mm

Model No.	d	l	Da	Dimension										Load Rating		K kgf/ μ m	
				D	A	B	L	W	H	X	Y	Z	Q	n	Ca (kgf)		Coa (kgf)
SFM03205-4*	32	5	3.175	48	74	12	52	60	60	6.5	11	6.5	M8	1x4	1922	6343	53
SFM0325T-4*		5.08	3.175	48	74	12	53	60	60	6.5	11	6.5	M8	1x4	1922	6343	53

※ ☆ Left helix available

3-10 Rolled Ball Screw Series

SFV Series Specifications

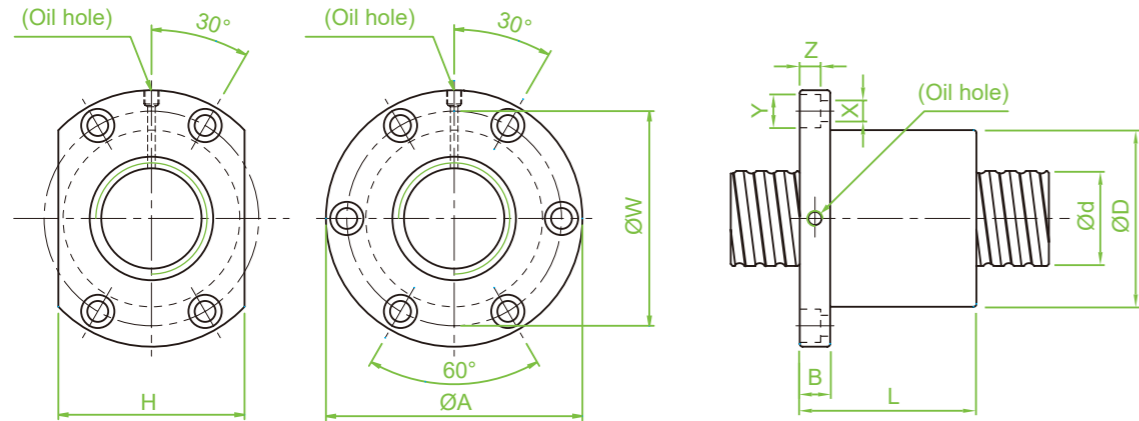

Unit : mm

Model No.	d	l	Da	Dimension											Load Rating		K kgf/μm
				D	A	B	L	W	H	X	Y	Z	Q	n	Ca (kgf)	Coa (kgf)	
SFV01205-2.8	12	5	2.5	30	50	10	42	40	32	4.5	8	4.5	M6	2.8x1	661	1316	19
SFV01210-2.7		10	2.5	30	50	10	53	40	32	4.5	8	4.5	M6	2.7x1	623	1241	18
SFV01604-3.8	16	4	2.381	34	57	11	45	45	34	5.5	9.5	5.5	M6	3.8x1	931	2285	31
SFV01605-4.8		5	3.175	40	63	11	58	51	42	5.5	9.5	5.5	M6	4.8x1	1614	3662	40
SFV01610-2.7	10	3.175	40	63	11	56	51	42	5.5	9.5	5.5	M6	2.7x1	1008	2161	24	
SFV02004-4.8	20	4	2.381	40	60	10	50	50	40	4.5	8	4	M6	4.8x1	1247	3584	45
SFV02005-4.8		5	3.175	44	67	11	57	55	52	5.5	9.5	5.5	M6	4.8x1	1814	4650	47
SFV02020-1.8	20	3.175	46	74	13	70	59	46	6.6	11	6.5	M6	1.8x1	764	1758	19	
SFV02505-4.8	25	5	3.175	50	73	11	55	61	52	5.5	9.5	5.5	M8	4.8x1	2017	5884	56
SFV02525-1.8		25	3.175	50	73	13	83	61	52	5.5	9.5	5.5	M8	1.8x1	843	2199	22
SFV03204-4.8	32	4	2.381	54	81	12	50	67	64	6.6	11	6.5	M6	4.8x1	1517	5806	62
SFV03205-4.8		5	3.175	58	85	12	56	71	64	6.6	11	6.5	M8	4.8x1	2249	7612	66
SFV03210-4.8	10	6.35	74	108	15	96	90	82	9	14	9	M8	4.8x1	5620	14649	76	
SFV04005-4.8	40	5	3.175	67	101	15	59	83	72	9	14	8.5	M8	4.8x1	2468	9586	76
SFV04010-4.8		10	6.35	82	124	18	100	102	94	11	17.5	11	M8	4.8x1	6316	18600	90
SFV04020-2.7	20	6.35	82	124	18	100	102	90	11	17.5	11	M8	2.7x1	3935	10893	56	
SFV05005-4.8	50	5	3.175	80	114	15	60	96	82	9	14	8.5	M8	4.8x1	2698	12053	87
SFV05010-4.8		10	6.35	93	135	16	93	113	98	11	17.5	11	M8	4.8x1	7023	23537	106
SFV05020-2.7	20	9.525	105	152	28	121	128	110	14	20	13	M8	2.7x1	7336	19700	68	
SFV06310-4.8	63	10	6.35	108	154	22	105	130	110	14	20	13	M8	4.8x1	7860	30430	126
SFV06320-2.7		20	9.525	122	180	28	120	150	130	18	26	17.5	M8	2.7x1	8162	24741	80
SFV08010-4.8	80	10	6.35	130	176	22	105	152	132	14	20	13	M8	4.8x1	8593	38344	145
SFV08020-4.8		20	9.525	143	204	28	180	172	148	18	26	18	M8	4.8x1	15103	57296	168
SFV08020-7.6	20	9.525	143	204	28	240	172	148	18	26	18	M8	3.8x2	22423	90719	260	

※Please contact LTROBOT if the marked types (●) are required.

SFY Series Specifications

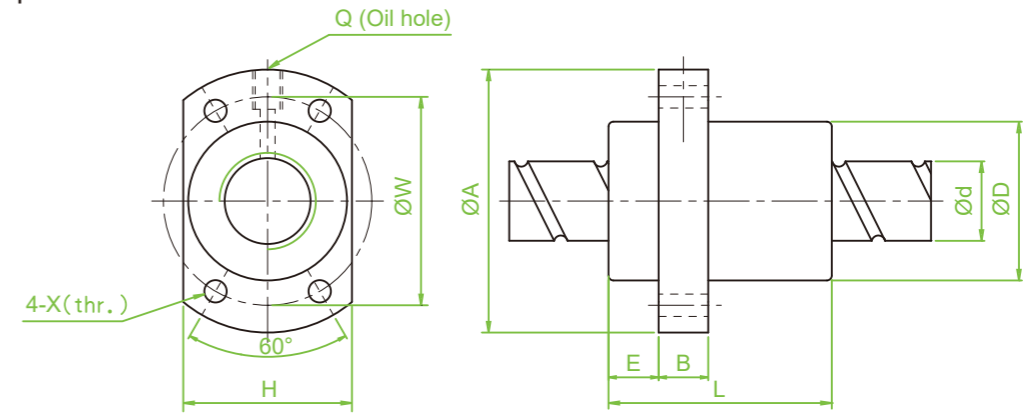

Unit : mm

Large Lead Model No.	d	l	Da	Dimension											Load Rating		K kgf/μm
				D	A	E	B	L	W	H	X	Q	n	Ca (kgf)	Coa (kgf)		
SFY01616-3.6	16	16	2.778	32	53	10.1	10	45	42	34	4.5	M6	1.8x2	1073	2551	31	
SFY02020-3.6	20	20	3.175	39	62	13	10	52	50	41	5.5	M6	1.8x2	1387	3515	37	
SFY02525-3.6	25	25	3.969	47	74	15	12	64	60	49	6.6	M6	1.8x2	2074	5494	45	
SFY03232-3.6	32	32	4.762	58	92	17	12	78	74	60	9	M6	1.8x2	3021	8690	58	
SFY04040-3.6	40	40	6.35	73	114	19.5	15	99	93	75	11	M6	1.8x2	4831	14062	70	
SFY05050-3.6	50	50	7.938	90	135	21.5	20	117	112	92	14	M6	1.8x2	7220	21974	86	
Twin Lead Model No.	d	l	Da	Dimension											Ca (kgf)	Coa (kgf)	K kgf/μm
SFY01632-1.6	16	32	2.778	32	53	10.1	10	42.5	42	34	4.5	M6	0.8x2	493	1116	11	
SFY02040-1.6	20	40	3.175	39	62	13	10	48	50	41	5.5	M6	0.8x2	653	1597	15	
SFY02550-1.6	25	50	3.969	47	74	15	12	58	60	49	6.6	M6	0.8x2	976	2495	19	
SFY03264-1.6	32	64	4.762	58	92	17	12	71	74	60	9	M6	0.8x2	1374	3571	22	
SFY04080-1.6	40	80	6.35	73	114	19.5	15	90	93	75	11	M6	0.8x2	2273	6387	29	
SFY050100-1.6	50	100	7.938	90	135	21.5	20	111	112	92	14	M6	0.8x2	3398	9980	35	

※Please contact LTROBOT if the marked types (●) are required.

XSX Series Specifications

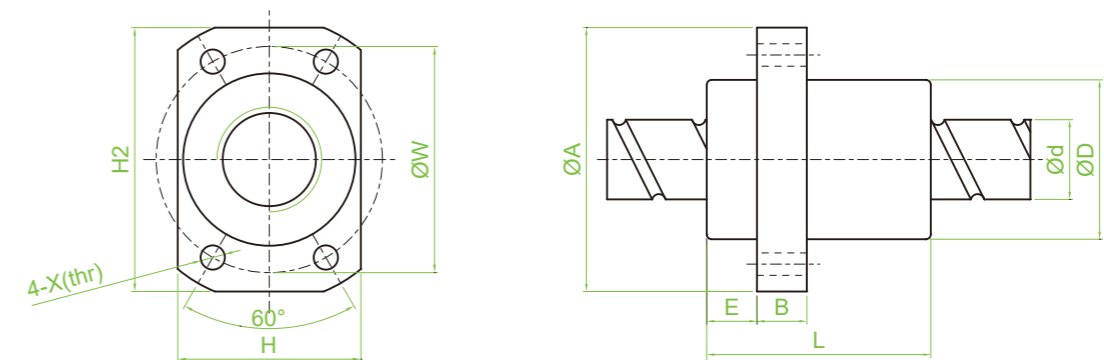

Unit : mm

Model No.	d	l	Da	Dimension											Load Rating		K kgf/μm
				D	A	E	B	L	W	H	H2	X	n	Ca (kgf)	Coa (kgf)		
XSXR01220A2D-00	12	20	2.5	24	41	3.8	5	50	32	24	36	4.5	1.8x2	777	1718	13	

3-10 Rolled Ball Screw Series

SCNI/SCI Series Specifications

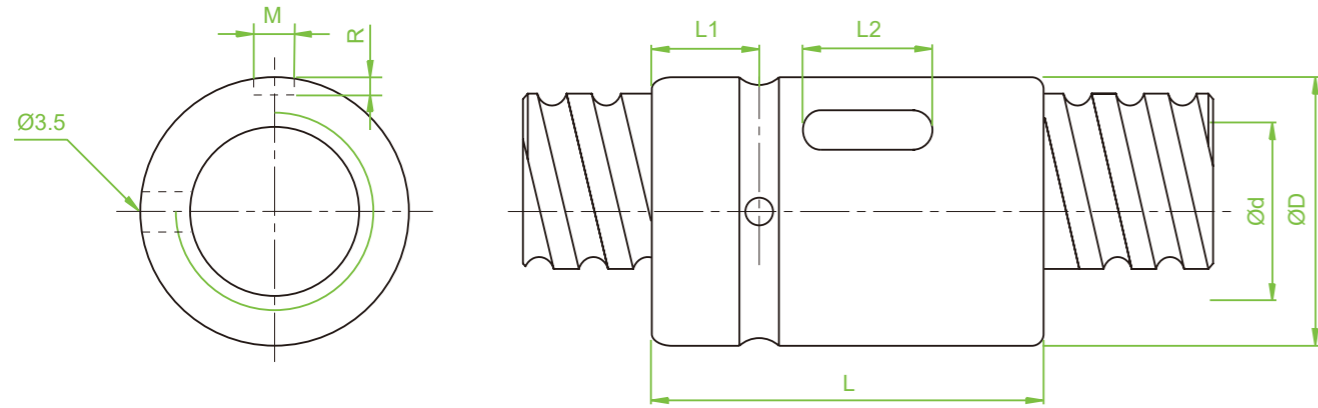

Unit : mm

Model No.	d	l	Da	Dimension							Load Rating		K kgf/μm
				D	L	L1	L2	M	R	n	Ca (kgf)	Coa (kgf)	
SCNI 01605-4	16	5	3.175	30	45	9	20	5	3	1x4	1380	3052	33
SCNI 02005-4	20	5	3.175	34	45	9	20	5	3	1x4	1551	3875	39
SCNI 02505-4	25	5	3.175	40	45	9	20	5	3	1x4	1724	4904	45
SCNI 02510-4		10	4.762	46	85	13	30	5	3	1x4	2954	7295	51
SCNI 03205-4	32	5	3.175	46	45	9	20	5	3	1x4	1922	6343	52
SCNI 03210-4		10	6.35	54	85	13	30	5	3	1x4	4805	12208	62
SCNI 04005-4	40	5	3.175	56	45	9	20	5	3	1x4	2110	7988	59
SCNI 04010-4		10	6.35	62	85	13	30	5	3	1x4	5399	15500	72
SCNI 05010-4	50	10	6.35	72	85	13	30	5	3	1x4	6004	19614	83
SCNI 06310-4	63	10	6.35	85	85	13	30	6	3.5	1x4	6719	25358	95
SCNI 08010-4	80	10	6.35	105	85	13	30	8	4.5	1x4	7346	31953	109
SCI 01604-4	16	4	2.381	30	40	9	15	3	1.5	1x4	973	2406	32
SCI 02004-4	20	4	2.381	34	40	9	15	3	1.5	1x4	1066	2987	37
SCI 02504-4	25	4	2.381	40	40	9	15	3	1.5	1x4	1180	3795	43
SCI 03204-4	32	4	2.381	46	40	9	15	3	1.5	1x4	1296	4838	49

※Please contact LTROBOT if the marked types (●) are required.

SFK Series Specifications

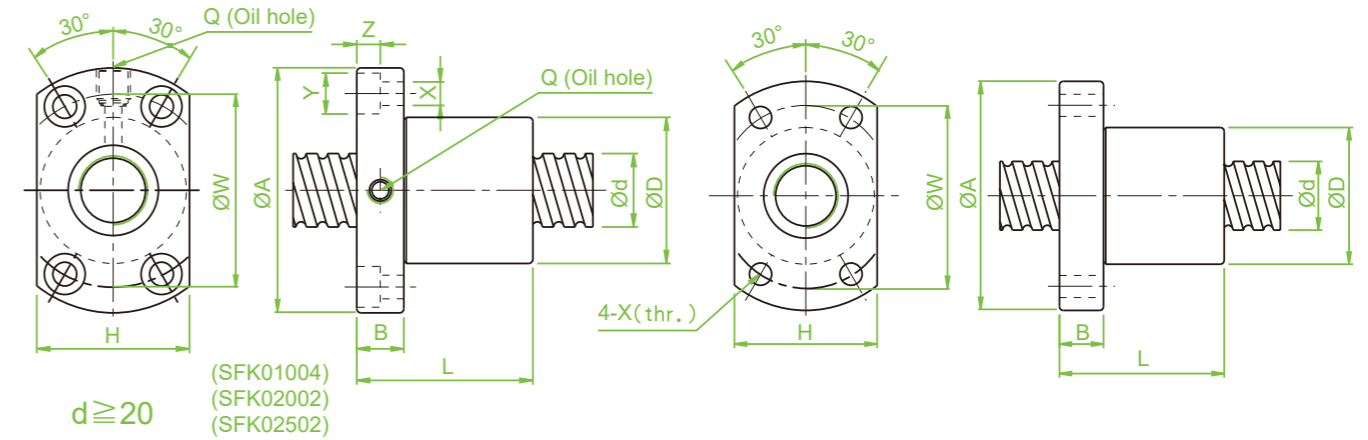

d ≥ 20

(SFK01004)
(SFK02002)
(SFK02502)

Unit : mm

Model No.	d	l	Da	Dimension											Ca (kgf)	Coa (kgf)	K kgf/μm
				D	A	B	L	W	H	X	Y	Z	Q	n			
SFK00601	6	1	0.8	12	24	3.5	15	18	16	3.4	—	—	—	1x3	111	224	9
SFK00801	8	1	0.8	14	27	4	16	21	18	3.4	—	—	—	1x4	161	403	14
SFK00802		2	1.2	14	27	4	16	21	18	3.4	—	—	—	1x3	222	458	13
SFK0082.5		2.5	1.2	16	29	4	26	23	20	3.4	—	—	—	1x3	221	457	13
SFK01002	10	2	1.2	18	35	5	28	27	22	4.5	—	—	—	1x3	243	569	15
SFK01004		4	2	26	46	10	34	36	28	4.5	8	4.5	M6	1x3	468	905	17
SFK01202	12	2	1.2	20	37	5	28	29	24	4.5	—	—	—	1x4	334	906	22
SFK01402	14	2	1.2	21	40	6	23	31	26	5.5	—	—	—	1x4	354	1053	24

Unit : mm

Model No.	d	l	Da	Dimension											Ca (kgf)	Coa (kgf)	K kgf/μm
				D	A	B	L	W	H	X	Y	Z	Q	n			
XSUR01204T3D-02	12	4	2.5	24	40	6	28	32	25	3.5	—	—	—	1x3	704	1413	—
XSUR01205T3D-00		5		22	37	8	39	29	24	4.5	—	—	—	1x3	702	1409	17

3-10 Rolled Ball Screw Series

BSH Series Specifications

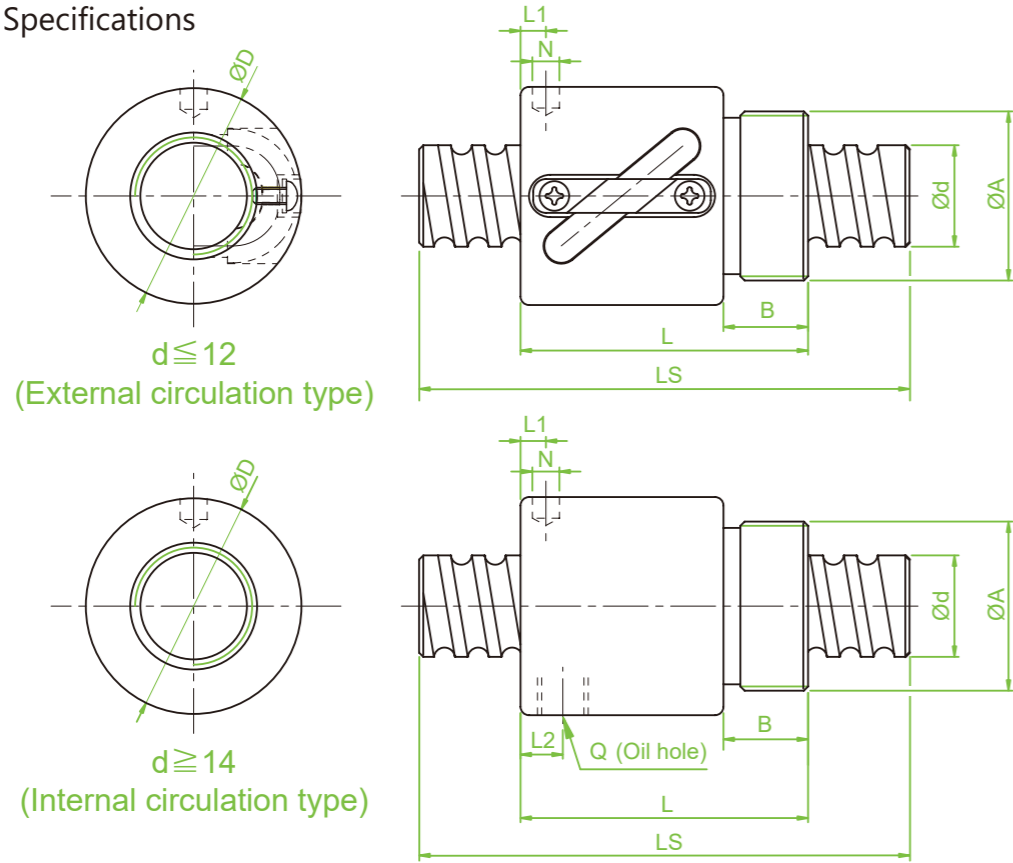

Unit : mm

Model No.	d	l	Da	Dimension									Ca (kgf)	Coa (kgf)	K kgf/μm
				D	A	B	L	L1	N	L2	Q	n			
BSHR0082.5-2.5	8	2.5	1.2	17.5	M15x1P	7.5	23.5	10	3	—	—	2.5x1	189	381	11
BSHR01002-3.5	10	2	1.2	19.5	M17x1P	7.5	22	3	3.2	—	—	3.5x1	277	664	17
BSHR01004-2.5		4	2	25	M20x1P	10	34	3	3	—	—	2.5x1	400	754	14
BSHR01204-3.5	12	4	2.5	25.5	M20x1P	10	34	13	3	—	—	3.5x1	804	1649	23
BSHR01205-3.5		5	2.5	25.5	M20x1P	10	39	16.25	3	—	—	3.5x1	801	1644	24
BSHR01404-3	14	4	2.5	32.1	M25x1.5P	10	35	11	3	—	—	1x3	748	1609	26
BSHR01604-3	16	4	2.381	29	M22x1.5P	8	32	4	3.2	—	—	1x3	759	1804	24
BSHR01605-3		5	3.175	32.5	M26x1.5P	12	42	19.25	3	—	—	1x3	1077	2289	25
BSHR01610-2		10	3.175	32	M26x1.5P	12	50	3	4	3	M4	1x2	779	1601	14
BSHR02005-3	20	5	3.175	38	M35x1.5P	15	45	20.3	3	—	—	1x3	1211	2906	30
BSHR02505-4	25	5	3.175	43	M40x1.5P	19	69	32.11	3	8	M6	1x4	1724	4904	37
BSHR02510-4		10	4.762	43	M40x1.5P	19	84	8	6	8	M6	1x4	2954	7295	41

※ Standard ballnut from Ø8~Ø16 is assembled without wiper.

Different brand compatible details

	CSK	ABBA	TBI	CPC	LTROBOT	LTROBOT	LTROBOT	PMI	PDF	THK	IKO	HIWIN
High profile with flange series	LMG15C	BRH15A	TRH15FL	HR15FN B/S	LDHW15CA	SGH15A	/	MSA15A	PDF15A	HSR15A	LWH(HT)15B	HGW15CA
	LMG20C	BRH20A	TRH20FL	HR20FN B/S	LDHW20CA	SGH20A	/	MSA20A	PDF20A	HSR20A	LWH(HT)20B	HGW20CA
	LMG20LC	BRH20AL	TRH20FE	HR20FL B/S	LDHW20HA	SGH20AL	/	MSA20LA	PDF20AL	HSR20LA	LWH(HT)G20B	HGW20HA
	LMG25C	BRH25A	TRH25FL	HR25FN B/S	LDHW25CA	SGH25A	/	MSA25A	PDF25A	HSR25A	LWH(HT)25B	HGW25CA
	LMG25LC	BRH25AL	TRH25FE	HR25FL B/S	LDHW25HA	SGH25AL	/	MSA25LA	PDF25AL	HSR25LA	LWH(HT)G25B	HGW25HA
	LMG30C	BRH30A	TRH30FL	HR30FN B/S	LDHW30CA	SGH30A	/	MSA30A	PDF30A	HSR30A	LWH(HT)30B	HGW30CA
	LMG30LC	BRH30AL	TRH30FE	HR30FL B/S	LDHW30HA	SGH30AL	/	MSA30LA	PDF30AL	HSR30LA	LWH(HT)G30B	HGW30HA
	LMG35C	BRH35A	TRH35FL	HR35FN B/S	LDHW35CA	SGH35A	SMH35A	MSA35A	PDF35A	HSR35A	LWH(HT)35B	HGW35CA
	LMG35LC	BRH35AL	TRH35FE	HR35FL B/S	LDHW35HA	SGH35AL	SMH35AL	MSA35LA	PDF35AL	HSR35LA	LWH(HT)G35B	HGW35HA
	LMG45C	BRH45A	TRH45FL	HR45FN B/S	LDHW45CA	SGH45A	SMH45A	MSA45A	PDF45A	HSR45A	LWH(HT)45B	HGW45CA
	LMG45LC	BRH45AL	TRH45FE	HR45FL B/S	LDHW45HA	SGH45AL	SMH45AL	MSA45LA	PDF45AL	HSR45LA	LWH(HT)G45B	HGW45HA
	LMG55C	BRH55A	TRH55FL	HR55FN B/S	LDHW55CA	SGH55A	SMH55A	MSA55A	PDF55A	HSR55A	LWH(HT)55B	HGW55CA
	LMG55CL	BRH55AL	TRH55FE	HR55FL B/S	LDHW55HA	SGH55AL	SMH55AL	MSA55LA	PDF55AL	HSR55LA	LWH(HT)G55B	HGW55HA
	LMG65C	BRH65A	TRH65FL	HR65FN B/S	LDHW65CA	SGH65A	SMH65A	MSA65A	PDF65A	HSR65A	LWH(HT)65B	HGW65CA
	LMG65CL	BRH65AL	TRH65FE	HR65FL B/S	LDHW65HA	SGH65AL	SMH65AL	MSA65LA	PDF65AL	HSR65LA	LWH(HT)G65B	HGW65HA

Low profile series	LMG15T	BRS15B	TRS15VN	AR15MN B/S	LDEH15CA	SGS15B	/	MSB15S	DFS15B	SR15W	LWES15	EGH15CA	
	LMG15ST	BRS15BS	TRS15VS	AR15MS B/S	LDEH15SA	/	/	MSB15TS	DFS15BS	SR15V	LWESC15	EGH15SA	
	LMG20T	BRS20B	TRS20VN	AR20MN B/S	LDEH20CA	SGS20B	/	MSB20S	DFS20B	SR20W	LWES20	EGH20CA	
	LMG20ST	BRS20BS	TRS20VS	AR20MS B/S	LDEH20SA	/	/	MSB20TS	DFS20BS	SR20V	LWESC20	EGH20SA	
	LMG25T	BRS25B	TRS25VN	AR25MN B/S	LDEH25CA	SGS25B	/	MSB25S	DFS25B	SR25W	LWES25	EGH25CA	
	LMG25ST	BRS25BS	TRS25VS	AR25MS B/S	LDEH25SA	/	/	MSB25TS	DFS25BS	SR25V	LWESC25	EGH25SA	
	LMG30T	BRS30BS	TRS30VN	AR30MN B/S		SGS30B	/	MSB30S	DFS30B	SR30W	LWESC30	EGH30CA	
	LMG30ST	BRS35B	TRS30VS	AR30MS B/S		/	/	MSB30TS	DFS30BS	SR30V	/	EGH30SA	
	LMG35T	BRH35A	TRS35VN	AR35MN B/S		SGS35B	SMS35B	MSB35S	DFS35B	SR35W	LWESC35	EGH35CA	
	LMG35ST	BRS35BS	TRS35VS	AR35MS B/S		/	SMS35BL	MSB35TS	/	SR35V	/	EGH35SA	
	LMG45T	BRS45B	TRS45VN	AR45MN B/S			SMH45A	SMS45B	MSB45S	DFS45B	SR45W	LWESC45	EGH45CA
	LMG45ST	BRS45BS	TRS45VS	AR45MS B/S		/	SMS45BL	MSB45TS	/	SR45V	/	EGH45SA	
	LMG55T	BRS55B	TRS55VN	AR55MN B/S		SGS55B	SMS55B	MSB55S	DFS55B	SR55W	LWESC55	EGH55CA	
	LMG55ST	BRS55BS	TRS55VS	AR55MS B/S		/	SMS55BL	MSB55TS	/	SR55V	/	EGH55SA	
	LMG65T	BRS65B	TRS65VN	AR65MN B/S		SGS65B	SMS65B	MSB65S	DFS65B	SR65W	LWESC65	EGH65CA	
LMG65ST	BRS65BS	TRS65VS	AR65MS B/S		/	SMS65BL	MSB65TS	/	SR65V	/	EGH65SA		

High profile without flange series	LMG15H	BRH15B	TRH15VL	HR15MN B/S	LDHH15CA	SGH15B	/	MSA15S	PDF15B	HSR15R	LWHD15B	HGH15CA
	LMG20H	BRH20B	TRH20VL	HR20MN B/S	LDHH20CA	SGH20B	/	MSA20S	PDF20B	HSR20R	/	HGH20CA
	LMG20LH	BRH20BL	TRH20VE	HR20ML B/S	LDHH20HA	SGH20BL	/	MSA20LS	PDF20BL	HSR20LR	/	HGH20HA
	LMG25H	BRH25B	TRH25VL	HR25MN B/S	LDHH25CA	SGH25B	/	MSA25S	PDF25B	HSR25R	LWHDG25B	HGH25CA
	LMG25LH	BRH25BL	TRH25VE	HR25ML B/S	LDHH25HA	SGH25BL	/	MSA25LS	PDF25BL	HSR25LR	LWH(HT)25B	HGH25HA
	LMG30H	BRH30B	TRH30VL	HR30MN B/S	LDHH30CA	SGH30B	/	MSA30S	PDF30B	HSR30R	LWHD30B	HGH30CA
	LMG30LH	BRH30BL	TRH30VE	HR30ML B/S	LDHH30HA	SGH30BL	/	MSA30LS	PDF30BL	HSR30LR	LWHDG30B	HGH30HA
	LMG35H	BRH35B	TRH35VL	HR35MN B/S	LDHH35CA	SGH35B	/	MSA35S	PDF35B	HSR35R	LWHD35B	HGH35CA
	LMG35LH	BRH35BL	TRH35VE	HR35ML B/S	LDHH35HA	SGH35BL	SMH35B	MSA35LS	PDF35BL	HSR35LR	LWHDG35B	HGH35HA
	LMG45H	BRH45B	TRH45VL	HR45MN B/S	LDHH45CA	SGH45B	SMH35BL	MSA45S	PDF45B	HSR45R	LWHD45B	HGH45CA
	LMG45LH	BRH45BL	TRH45VE	HR45ML B/S	LDHH45HA	SGH45BL	SMH45B	MSA45LS	PDF45BL	HSR45LR	LWHDG45B	HGH45HA
	LMG55H	BRH55B	TRH55VL	HR55MN B/S	LDHH55CA	SGH55B	SMH45BL	MSA55S	PDF55B	HSR55R	LWHD55B	HGH55CA
	LMG55LH	BRH55BL	TRH55VE	HR55ML B/S	LDHH55HA	SGH55BL	SMH55BL	MSA55LS	PDF55BL	HSR55LR	LWHDG55B	HGH55HA
	LMG65H	BRH65B	TRH65VL	HR65MN B/S	LDHH65CA	SGH65B	SMH65B	MSA65S	PDF65B	HSR65R	LWHD65B	HGH65CA
	LMG65LH	BRH65BL	TRH65VE	HR65ML B/S	LDHH65HA	SGH65BL	SMH65BL	MSA65LS	PDF65BL	HSR65LR	LWHDG65B	HGH65HA